



Town of East Gwillimbury



Engineering Standards and Design Criteria September 2012

Table of Contents

SECTION A – GENERAL INFORMATION	1
1.0 INTRODUCTION	1
1.1 Familiarization	1
2.0 MISCELLANEOUS SUBMISSION REQUIREMENTS	1
2.1 Ministry of the Environment (MOE) Applications	1
2.2 Miscellaneous Approvals	2
2.3 Original Drawings	2
2.4 Requirements Prior to Commencement of Construction	2
SECTION B – SURVEY REQUIREMENTS	3
3.0 SURVEY CONTROL MONUMENTS.....	3
SECTION C – DRAWING AND SUBMISSION REQUIREMENTS	4
4.0 SUBMISSION REQUIREMENTS	4
5.0 ENGINEERING DRAWING REQUIREMENTS	4
6.0 GENERAL SERVICES PLAN	5
7.0 PLAN AND PROFILE DRAWINGS.....	6
8.0 LOT GRADING PLANS	8
9.0 COMPOSITE UTILITY PLANS	8
10.0 OTHER DRAWINGS	9
10.1 Traffic Management Plans.....	9
10.2 Drainage Plans	9
10.3 Tree Preservation Plans	9
10.4 Erosion and Sedimentation Control Plans	9
10.5 Detail Drawings	10
10.6 Landscaping Drawings	10
11.0 RECORD DRAWINGS	10
11.1 General.....	10
11.2 Record Field Survey	10
11.3 Materials	11
11.4 Drawing Revisions.....	11
11.5 Submission of Record Drawings.....	12
SECTION D – TRANSPORTATION	13
12.0 ROAD CLASSIFICATIONS.....	13
13.0 SUPPORTING TRAFFIC STUDIES	13
14.0 GEOMETRIC DESIGN ELEMENTS.....	14
15.0 DESIGN ELEMENTS	15

15.1	Typical Road Cross Sections.....	15
15.2	Vertical Curves	15
15.3	Backfall at Intersecting Streets	15
15.4	Curb Return Radii at Intersections.....	15
15.5	Daylighting Requirements at Intersections	15
15.6	Cul-de-sacs	16
15.7	Temporary Turning Circles	16
15.8	Location of Utilities	16
15.9	Transit	17
15.10	Accessibility Guidelines	17
16.0	TRAFFIC CONTROLS	17
16.1	Signage	17
16.2	Street Name Signs	17
16.3	Regulatory Traffic Control and Advisory Signage	18
16.4	Pavement Markings.....	18
17.0	PAVEMENT DESIGN	19
17.1	Road Sub-Drains	19
18.0	CONCRETE CURB AND GUTTER.....	20
19.0	SIDEWALKS	20
20.0	DRIVEWAYS.....	21
20.1	Minimum Driveway Design	21
20.2	Driveway Grades	21
20.3	Driveway Depressions.....	21
20.4	Walkways	21
21.0	BOULEVARDS	22
21.1	Placing of Final Surface Course Asphalt	23
	SECTION E – LOT GRADING	24
22.0	GENERAL.....	24
22.1	Objectives.....	24
23.0	LOT GRADING CRITERIA.....	24
23.1	Type of Drainage Pattern	24
23.2	Specified House Grade (SHG)	25
23.3	Slopes	26
23.4	Swales.....	27
23.5	Rear Lot Catchbasins	27
23.6	Sodding and Ground Cover Requirements.....	28
24.0	RETAINING WALLS	28
25.0	LOT GRADING CERTIFICATION.....	29
	SECTION F – SANITARY SEWERS AND APPURTENANCES	32
26.0	HYDRAULIC DESIGN.....	32

26.1	Confirmation of Capacity	32
26.2	Sanitary Drainage Plan.....	32
26.3	Calculation of Sewage Flows.....	32
26.4	Average Daily Flows.....	33
26.5	Extraneous Flows	33
26.6	Design Populations.....	33
27.0	SANITARY SEWER DESIGN	34
27.1	Location.....	34
27.2	Pipe Capacities.....	34
27.3	Minimum Size	35
27.4	Minimum and Maximum Grades.....	35
27.5	Minimum and Maximum Depths	35
27.6	Curved Sewers	35
27.7	Termination Points.....	35
27.8	Pipe Crossings	35
27.9	Changes in Pipe Size	36
27.10	Pipe Bedding	36
28.0	MANHOLES	36
28.1	Location.....	36
28.2	Maximum Spacing	36
28.3	Manhole Types.....	36
28.4	Manhole Frame and Covers	37
28.5	Head Losses.....	37
28.6	Manhole Design.....	38
28.7	Drop Structures	38
29.0	SANITARY SERVICE CONNECTIONS	38
29.1	General.....	38
29.2	Location	38
29.3	Size	38
29.4	Connection to Main.....	39
29.5	Depth.....	39
29.6	Grades.....	39
29.7	Connection to Multiple Family and Other Blocks	39
29.8	Connection to Commercial/Industrial Institutional Blocks	40
29.9	Connection to Park Blocks	40
30.0	PIPE MATERIALS	40
31.0	SANITARY PUMPING STATIONS	40
SECTION G – STORM DRAINAGE & STORMWATER MANAGEMENT		41
32.0	STORM DRAINAGE POLICIES.....	41
32.1	Planning, Policies and Design Criteria.....	41
32.2	Levels of Service	42
32.3	Hydrology and Hydrologic Modelling	42
33.0	STORMWATER MANAGEMENT POND DESIGN	43

33.1	Operational and Maintenance Features	45
33.2	Operations and Maintenance Manual	45
34.0	STORMWATER CONVEYANCE SYSTEM SIZING	46
34.1	General	46
34.2	Minor Drainage System Design	47
34.3	Major Drainage System Design	50
34.4	Foundation Drain Collector Systems	52
35.0	STORMWATER CONVEYANCE SYSTEM DESIGN	52
35.1	Pipe Cover	52
35.2	Location	52
35.3	Termination Points	53
35.4	Sewer Alignment	53
35.5	Pipe Crossings	53
35.6	Changes in Pipe Size	53
35.7	Pipe Bedding and Backfill	53
36.0	MANHOLES	53
36.1	Location	53
36.2	Maximum Spacing of Manholes	54
36.3	Manhole Types	54
36.4	Manhole Frame and Covers	54
36.5	Manhole Design	54
36.6	Drop Structures	55
36.7	Head Losses through Manholes	55
36.8	Prefabricated Wyes	55
36.9	Radius Pipe	56
37.0	CATCHBASINS	56
37.1	Location and Spacing	56
37.2	Catchbasin Capture	57
37.3	Catchbasin Types	57
37.4	Catchbasin Connections	57
37.5	Catchbasin Frame and Covers	57
38.0	STORM SERVICE CONNECTIONS	58
38.1	General	58
38.2	Location	58
38.3	Size	58
38.4	Connection to Main	58
38.5	Depth	59
38.6	Connection to Multiple Family and Other Blocks	59
38.7	Connection to Commercial/Industrial Institutional Blocks	59
39.0	INLETS, OUTFALLS AND SPECIAL STRUCTURES	59
39.1	Inlets	59
39.2	Outlets	60
39.3	Safety Railings	60

40.0	PIPE MATERIALS	60
41.0	SUBMISSION REQUIREMENTS FOR SWM DESIGN REPORTS.....	60
	SECTION H – WATERMAINS AND APPURTENANCES	63
42.0	HYDRAULIC DESIGN.....	63
42.1	General.....	63
42.2	Fire Flow.....	63
42.3	System Pressures	63
42.4	Flow Design.....	63
42.5	Domestic Demand.....	64
42.6	Industrial, Commercial and Institutional (ICI) Water Demands	64
42.7	Locations.....	64
42.8	Depth of Cover	65
42.9	Horizontal Separation between Sewers and Watermains.....	65
42.10	Watermain Crossing Sewers and Other Utilities.....	65
42.11	Dead-Ends.....	65
42.12	Location Identification.....	65
42.13	Joint Restraint.....	66
43.0	VALVE REQUIREMENTS.....	66
43.1	Special Valves	67
44.0	FIRE HYDRANT REQUIREMENTS	67
44.1	Spacing	67
44.2	Type	67
44.3	Branch Valves and Boxes	68
44.4	Location of Hydrants.....	68
44.5	Hydrant Flow Testing.....	68
45.0	SERVICE CONNECTIONS	68
45.1	General.....	68
45.2	Material.....	68
45.3	Minimum Size	68
45.4	Location.....	69
45.5	Markers	69
45.6	Connections to Supply Main.....	69
45.7	Curb Stops.....	69
46.0	COMMERCIAL AND INDUSTRIAL CONNECTION	69
47.0	CONNECTION TO PARK BLOCKS	69
48.0	CORROSION PROTECTION.....	69
49.0	MATERIALS.....	70
50.0	WATER SAMPLE STATIONS	70
	SECTION I – UTILITIES & STREET LIGHTING.....	71
51.0	GENERAL.....	71

51.1 Standard Requirements..... 71

52.0 COMPOSITE UTILITY DRAWINGS..... 71

53.0 STREET LIGHTING DESIGN..... 73

53.1 Street Light Poles and Fixtures..... 73

53.2 Street Light Pole Spacing 73

53.3 Shop Drawing Review 73

53.4 Energization of Street Lighting System..... 73

53.5 Alternate Street Lighting Designs 73

SECTION J – EASEMENT REQUIREMENTS..... 75

54.0 GENERAL..... 75

54.1 Rear Yard Catchbasin Leads..... 75

54.2 Storm, Sanitary Sewer and Watermain Easements..... 75

54.3 Concrete Encasement..... 76

54.4 Pipes Constructed in Sleeves..... 76

APPENDICES

APPENDIX 1 – LIST OF ACCEPTABLE MATERIALS

APPENDIX 2 – STANDARDS DRAWINGS

APPENDIX 3 – SANITARY SEWER DESIGN SHEET

APPENDIX 4 – STORM SEWER DESIGN SHEET

APPENDIX 5 – DESIGN STORMS

APPENDIX 6 – TYPICAL ENGINEERING DRAWINGS



Town of
East Gwillimbury

SECTION A

GENERAL INFORMATION

Town of East Gwillimbury
Engineering Standards and Design Criteria

September 2012

SECTION A – GENERAL INFORMATION

1.0 INTRODUCTION

The material presented herein is intended as a guideline in the production of designs for roads and services for all land development projects within the Town of East Gwillimbury. While specific design guidelines are provided herein, the **Ontario Provincial Standard Drawings and Specifications** supply the basis for much of the construction activity and shall be adhered to at all times unless directed otherwise by these design guidelines.

The design of all municipal services in the Town of East Gwillimbury is to be based upon the specifications and standards in effect at the time of submission. It is incumbent upon the Developer's Consulting Engineer to ensure the latest specifications are being utilized. All plans are to be accepted by the Town before they are used for the construction of services however, such acceptance in no way relieves the Developer's Consulting Engineer from providing an adequate and safe design.

1.1 Familiarization

Prior to the commencement of the engineering design, the Consultant shall obtain copies of the Town's current Engineering Standards and Design Criteria Manual, Standard Detailed Drawings and Parkland Design Standards Manual to familiarize themselves with the requirements of subdivision design in the municipality. Meetings shall be held with the Town's Engineering and Planning staff to discuss areas of preliminary concern and other issues prior to commencement of the engineering design.

All design work shall adhere to the approval principles as determined through the functional reports provided and adopted during the draft plan approval stage of the process.

2.0 MISCELLANEOUS SUBMISSION REQUIREMENTS

2.1 Ministry of the Environment (MOE) Applications

After the engineering design and drawings are prepared to the satisfaction of the Town, three (3) copies of the MOE Application Forms for Sanitary and Storm Sewers and Stormwater Management Facilities and one (1) complete set of engineering drawings shall be submitted to the Town's General Manager of Community Programs and Infrastructure or Designate. These copies will be signed on behalf of the Town and returned to the Developer's Consulting Engineer. The Developer's Consulting Engineer will then make application to the MOE (or the Region of York for those works under the Transfer of Review Program) for approval under the Ontario Water Resources Act.

The Town of East Gwillimbury has been issued a Municipal Drinking Water Licence from the MOE under Part 5 of the Safe Drinking Water Act. Accordingly, watermain designs are not to be submitted to the MOE for approval. A completed "Form 1 – Record of Watermains" is to be submitted to the Town together with a General Services

Plan showing the watermains described in the form in lieu of making a submission to the MOE.

2.2 Miscellaneous Approvals

The Developer's Consulting Engineer is required to make all submissions and representations necessary to obtain approvals from all other authorities affected (Region of York, Ministry of Transportation, Ministry of Natural Resources, Fisheries Canada, Lake Simcoe Region Conservation Authority, CNR, Canada Post Corporation, Utility Companies, etc). The Town of East Gwillimbury shall be kept informed of the progress of these submissions by copies of all correspondence.

2.3 Original Drawings

After acceptances have been received from all applicable agencies, the original drawings shall be submitted to the General Manager of Community Programs and Infrastructure or Designate for review and/or acceptance. A mylar copy of the final signed accepted drawings and a digital copy in electronic format (AutoCAD, Ver. 2009 or latest version) shall be provided to the Town. The information contained on all drawings must be referenced to a geodetic datum. Any subsequent changes must be formally submitted to the Town for approval.

If after one year from the date of the signing of the drawings by the Town, the Developer fails to enter into a Subdivision Agreement with the Town, the Town reserves the right to revoke any or all approvals related to the engineering drawings.

2.4 Requirements Prior to Commencement of Construction

Prior to the commencement of construction, the Developer/Developer's Consulting Engineer shall submit the following information to the Town:

- a) two (2) sets of full size drawings and construction specifications along with two (2) sets of reduced size drawings (11" x 17")
- b) the names of the proposed Contractor and any Sub-contractors
- c) the Contractor's list of suppliers
- d) a copy of the signed contract tender complete with prices
- e) securities as outlined in the Subdivision Agreement in a form acceptable to the Town
- f) proof of public liability insurance with minimum coverage of 5 million dollars naming the Town of East Gwillimbury and the Town's Checking Consultant as additional insured
- g) any other information as required by the Town or as specified in the Subdivision Agreement.



Town of
East Gwillimbury

SECTION B

SURVEY REQUIREMENTS

Town of East Gwillimbury
Engineering Standards and Design Criteria

September 2012

SECTION B – SURVEY REQUIREMENTS

3.0 SURVEY CONTROL MONUMENTS

Prior to the assumption of the subdivision, the Owner's Surveyor shall establish a network of second order horizontal control monuments, as set out in "Ontario Specifications for Horizontal Control Surveys (OS 79)", as well as a network of vertical control benchmarks, as set out in "Ontario Specifications for Vertical Control Surveys (OS 79)".

The same monument may be used as both a horizontal and vertical control monument/benchmark.

The horizontal control monuments, and the vertical control benchmarks, shall be established at approved locations to the satisfaction of the Town, using the following criteria:

- Two (2) horizontal control monuments and two (2) vertical control benchmarks for the first ten hectares (10 ha) (or less) subdivided by the plan, and one (1) additional horizontal control monument and vertical control benchmark for every additional ten hectares (10 ha) (or less) subdivided by the plan.
- In addition, every existing horizontal control monument and vertical control benchmark destroyed during subdivision or site plan construction must be replaced.
- The new horizontal control monuments and vertical control benchmarks (including replacements) shall be installed by an Ontario Land Surveyor. A certificate will be required from an Ontario Land Surveyor stating that the horizontal control monuments and vertical control benchmarks were installed as set out by the "Ontario Specifications for Horizontal Control Surveys (OS 79)" and the "Ontario Specifications for Vertical Control Surveys (OS 79)" respectively. In addition confirmation will be required from the Ministry of Natural Resources that the horizontal control monuments and vertical control benchmarks have been accepted into their Cosine Database.
- The horizontal control monument shall in accordance with Town of East Gwillimbury Standard Drawing included in the Appendix to this document.
- The location, description and pertinent information with respect to the monuments shall be indicated on all engineering drawings.



Town of
East Gwillimbury

SECTION C

DRAWING AND SUBMISSION REQUIREMENTS

Town of East Gwillimbury
Engineering Standards and Design Criteria

September 2012

SECTION C – DRAWING AND SUBMISSION REQUIREMENTS

4.0 SUBMISSION REQUIREMENTS

Two sets of full size engineering drawings and supporting documents meeting the requirements set out below together with one digital (pdf) version of all documents submitted shall be included with each submission made to the Town.

5.0 ENGINEERING DRAWING REQUIREMENTS

- a) A title/cover sheet is required for the drawings. The standard cover sheet is available digitally in AutoCAD format upon request from the Town Engineering Department. An example of this drawing is located in the Appendix to this document.
- b) The following information shall be included on the cover sheet:
 - Key plan with scale
 - Name of Project (Subdivision or Site Plan)
 - Subdivision T number (ie. 19T-XXXXX)
 - Developer name and contact Information
 - Consultant name and contact information
 - Drawing Index
 - Legal information (Lot, Concession and M-Plan number if available)
 - Town of East Gwillimbury name and logo.
 - A Drawing Notes page containing standard notes that apply to the municipality is available digitally. A sample drawing is included in the Appendix to this document.
- a) All drawings shall be prepared using the current version of AutoCAD in use by the Town at the time of the submission. All plans shall be prepared on standard ISO A1 594 mm x 841 mm sheets. Final signed plans shall be plotted on standard bond paper.
- b) Standard digital title blocks are to be used and are available in AutoCAD format upon request from the Town Engineering Department. Examples are located in Appendix to this document.
- c) All elevations shown on the drawings are to be of geodetic origin and reference to the geodetic benchmark is required. Town benchmark information is available upon request from the Town Engineering Department.
- d) All existing and proposed road allowances, lot lines, lot numbers, block numbers, and intended purpose for blocks (i.e. school, park, etc.), easements reserves and street names are to be included on the drawings.
- e) Regional floodlines are to be indicated on all plans affected.

- f) A north arrow shall be referenced at the top right hand corner of all drawings. North shall generally point to the top of the drawings.
- g) Stationing shall be from left to right.
- h) A key plan drawn to 1:10000 scale shall be shown on all plans with the exception of detail drawings. The area covered by the drawing shall be clearly identified. The key plan shall show at least one major intersection in relation to the project.
- i) All engineering drawings shall be stamped by a Professional Engineer. The Engineer's stamp must be signed and dated, prior to the issuance of drawings for signature by the Town's General Manager of Community Programs and Infrastructure.

6.0 GENERAL SERVICES PLAN

- a) A drawing showing General Services shall be prepared for all developments at a maximum scale of 1:1000.
- b) The reference geodetic benchmark and the site benchmarks to be used for construction shall be identified on the Cover Sheet and all relevant plans.
- c) A drawing index shall be shown on all General Services Plans to identify the Plan and Profile Drawing Number for each street or easement shown.
- d) All streets shall have the approved street names indicated (once available).
- e) All existing services, utilities and abutting properties are to be shown in dashed/grayscale lines. All proposed services to be constructed are to be shown in solid lines.
- f) All manholes will be shown and are to be numbered in accordance with the design sheets. Sanitary manholes shall include the letter "A" after the number designation. All catchbasins are to be shown.
- g) All existing and proposed storm and sanitary sewers are to be shown including size, length, grade, direction of flow, material and type of the sewer. Storm sewers 900 mm dia. and larger are to be drawn with two lines. Services must be shown for all lands to be registered. Services are to be terminated at the subdivision limits.
- h) All watermains, valves, valve chambers, sampling stations and hydrants are to be shown. Watermains are to be identified only by size and material.
- i) All curbs and sidewalks are to be shown, including details of connections to existing sidewalk networks.
- j) All fencing is to be indicated by height and type.
- k) All sites for parks, schools, churches, commercial and industrial developments must be shown and clearly identified.

- l) If a subdivision encroaches on an existing floodplain, the approved fill and floodline restrictions must be shown, as specified by the Lake Simcoe Region Conservation Authority.
- m) All existing buildings and structures on the lands including ones which are to be removed are to be shown and labelled.
- n) The location of all traffic control and information signs and line painting is to be clearly shown on separate Traffic Management Plans, not on the General Services Plan.

7.0 PLAN AND PROFILE DRAWINGS

- a) All Plan and Profile Drawings shall be prepared at a scale of 1:500 horizontally and 1:100 vertically. A complete legend shall be provided on each drawing.
- b) Plan and Profile Drawings are required for all roads, blocks and easements where services are proposed, for all outfalls and for all boundary roadways abutting the development.
- c) All existing or future services, utilities and abutting properties shall be shown in dashed/grayscale lines.
- d) All services to be constructed are to be shown in solid lines.
- e) All road allowances, lots, blocks, easements and reserves are to be identified. Lot and block frontages are to be dimensioned.
- f) All curb, gutter and sidewalks are to be shown and dimensioned on the plan portion of the drawings.
- g) All sewers and culverts shall be shown and dimensioned on the plan and shall also be plotted on the profile of the drawings to true scale size. For all sewers and culverts, the type, size, slope, length, material and direction of flow shall be shown on both the plan and profile portion of all drawings. Storm sewers 900 mm dia. and larger are to be drawn with two lines in the plan portion. The hydraulic grade line for the storm sewer shall be drawn and labeled on the profile portion of the drawings.
- h) All manholes shall be shown on the plan and profile portion of the drawings. The manholes shall be identified by number on the plan portion and by number, chainage, offset, size, invert elevations and applicable Ontario Provincial Standard Drawing on the profile portion of the drawing. Sanitary manholes shall include the letter "A" after the number designation. Manholes that have safety platforms or drop connections shall be noted.
- i) All non-standard manholes are to be detailed on the plan portion of the drawing at a scale of 1:50 and in relation to the north arrow.
- j) All catchbasins and catchbasin connections shall be shown. All grate and invert elevations for rear lot catchbasins are to be shown. Concrete encasement shall be shown on all rear lot catchbasin leads.

- k) When streets are of a length that requires more than one drawing, match lines are to be used with no overlapping of information.
- l) The reference drawing numbers for all intersecting streets and match lines shall be shown on all Plan and Profile Drawings.
- m) All watermains, hydrants, valves, etc., shall be described and dimensioned on the plan portion of the drawings. The watermain is to be plotted to true scale size and shaded on the profile portion of the drawing and shall be described.
- n) The location of all storm, water and sanitary service connections shall be shown on the plan portion of the drawings.
- o) The centreline of construction with 20.0 metre stations shall be noted with a small cross on the plan portion of the drawings. Chainage shall generally start on the left side of the sheet and increase from left to right on all drawings. Existing and proposed centreline elevations shall be shown at 20.0 metre intervals along the bottom of the profile.
- p) The original and proposed ground at centreline of road shall be plotted on the profile. The proposed profile shall be fully described (length, grade, V.P.I. elevations, vertical curve data, etc.) with all elevations shown to two decimal places with the exception of the V.P.I. which shall be to three decimal places. Chainage for the centreline of construction as well as the chainages for V.P.I., B.V.C., E.V.C. shall be noted on the profile portion of the drawings.
- q) Details of the gutter grades for all intersections, cul-de-sacs and expanded bulbs shall be provided on the plan portion as a separate detail at a scale of 1:200.
- r) Chainage for the centreline of construction, including chainages for P.I., B.C., E.C. and horizontal curve data shall be shown on the plan portion of the drawings.
- s) The proposed pavement structure design and dimensions shall be noted on the plan portion of the drawings.
- t) All existing utilities and services shall be shown on the plan view of the drawings. Utility locates will be required to determine the extent and location of existing utilities. It may be necessary to dig test holes to determine the actual elevations of these services to avoid conflicts with new construction. These elevations shall be shown on the profile portion of the drawings.
- u) Profiles of roadways shall be produced sufficiently beyond the limits of the proposed roads to confirm the feasibility of future extensions, or connections to existing lands.
- v) In addition to the above, the following details shall be shown on the plan portion of the drawings:
 - the curb radii at all intersections
 - the location of all luminaire poles and transformers
 - any special notes.

8.0 LOT GRADING PLANS

- a) All Lot Grading Plans shall be prepared in accordance with the criteria outlined in Section E of this document.
- b) The plans shall be prepared at a scale of 1:500.
- c) The plans must show overall lot fabric with lot and block numbers, street names, right-of-way limits, road curb and gutters, catchbasins, sidewalks and driveway locations. The plans shall show existing topographic information, including existing contours and contour labels at an elevation interval of 0.50 m and shall extend 30 m beyond the limits of the project. Above ground street furniture is not to be shown.
- d) All internal block details shown on this plan are schematic only and are not to be considered to be included in the Town of East Gwillimbury approval of the plan. Final building, drainage and grading details for each block shall be subject to the Town's Site Plan Approval. Drainage of all blocks is to be self contained.
- e) Road grades shall be shown at 20 metre intervals and at all changes in grade. Directional arrows shall be provided indicating the overland flow route. 100 year storm event ponding limits shall also be shown where applicable.
- f) Existing and proposed grades at the lot corners shall be indicated along with elevations at any break points and swales. Existing and proposed retaining walls, including top and bottom elevation, and existing and proposed embankments including slope label and associated elevations shall be shown.
- g) Any lots requiring more than 1.2 metres of fill shall be indicated with an asterisk (*) beside the lot number to show that either engineered fill or extended footings may be required.
- h) The house type and specified house grade is to be shown for all lots. Minimum basement elevations are to be shown where ground water or hydraulic gradeline impacts are a concern.
- i) Directional arrows shall be provided on all lots indicating the direction of flow and grade of flow in percent (%) along rear lots lines.
- j) All existing trees are to be shown. All trees are to be clearly identified with appropriate shading as "to be preserved" or "to be removed". The base elevation and size of all existing trees is also to be shown.
- k) Any existing structures shall be shown with notes clearly identifying whether they are to be retained or demolished/decommissioned.

9.0 COMPOSITE UTILITY PLANS

- a) A Composite Utility Plan (or Plans) is to be prepared in accordance with the criteria outlined in Section I of this document.
- b) The plans shall be prepared at a scale of 1:500.

- c) The plans must show overall lot fabric with lot and block numbers, municipal addresses, street names, right-of-way limits, road curb and gutters, catchbasins, sidewalks, street trees, all aboveground street furniture and driveway locations.
- d) Typical road cross-sections must be included on the plans.
- e) Table I-1 indicating Public Utility Clearance Requirements must be included on all plans.
- f) The location of all utilities (above and below ground) must be clearly shown (hydro, telecommunications, gas, cable, streetlighting) along with Canada Post mailbox locations.
- g) The location of all utility service locations to lots must be clearly identified along with storm, sanitary and water connections. All utility road crossings, including the number of ducts in each, and whether crossings are to be direct buried, conduit, or concrete encased conduit are to be shown.
- h) Details shall be included indicating location and spacing requirements of services for the various lot types in the development.
- i) A signature block shall be included for each utility to sign indicating acceptance of the layout as shown.

10.0 OTHER DRAWINGS

10.1 Traffic Management Plans

Traffic Management Plans at a scale of 1:1000 are to be prepared indicating the location and details for all traffic control and information signage and line painting.

10.2 Drainage Plans

Drainage plans shall be prepared at a scale of 1:1000. All drainage plans for the storm and sanitary sewer design shall be prepared in accordance with the criteria provided in Sections F and G of this document. Manhole labels shall be presented at a legible text size appropriate for the scale.

10.3 Tree Preservation Plans

Prior to any site disturbance taking place plans will be required indicating the measures that will be put in place to protect any trees to be preserved. The plans shall clearly show the location and details for all tree protection fences and any other measures necessary to protect trees. The proposed measures shall be in accordance with the Town's Parkland Design Standards Manual.

10.4 Erosion and Sedimentation Control Plans

Prior to any site disturbance taking place plans will be required indicating the measures that will be put in place to prevent the migration of any silts from the site. The plans shall clearly indicate the order in which all activities are to take place and shall show the

location and details for all silt control fences, earth or rock check dams, sediment ponds, mud mats and any other measures necessary to control silts. Topsoil stockpile locations shall also be indicated on the drawings. Sediment pond sizing calculations and temporary outfall details are also to be shown.

10.5 Detail Drawings

The Town of East Gwillimbury Standard Drawings shall be used whenever applicable. In the absence of a Standard Drawing the latest revision of the Ontario Provincial Standard Drawings shall be used. Individual details shall be provided by the Developer's Consulting Engineer for all special features not covered by any of the above. All details shall be reproduced or drawn on standard size sheets and shall be included as part of the engineering drawings.

10.6 Landscaping Drawings

Drawings indicating the location and species of street trees, stormwater management pond landscaping, trails, trailheads, viewparks and park and open space landscaping shall be prepared in accordance with the Town's Parkland Design Standards Manual and the requirements of the Town's Landscape Architect. These plans shall be submitted separately for review/approval to the Town's Parks/Leisure Services Branch.

All final approved landscaping drawings shall be bound and included with the final approved engineering drawings in one package.

11.0 RECORD DRAWINGS

11.1 General

The Record Drawings constitute the original (design) engineering drawings which were accepted by the Town and which have been amended to incorporate the construction changes and variances in order to provide accurate information of the works as installed in the development. Submission of record drawing information shall be accompanied by revised design calculation sheets which confirm the capacity of the constructed condition of the sewers. Drawings shall be submitted during the maintenance period, prior to issuance of Final Acceptance. Record Drawings shall be prepared in accordance with PEO guidelines.

11.2 Record Field Survey

The Record Drawing revisions shall be based on a final survey of all the subdivision services and the Developer's Consulting Engineer's construction records. The final survey shall include a final check of the following items:

- location of all manholes, including invert and top of cover elevations
- distances and pipe slopes between all manholes
- location of all roadway catchbasins

- location, rim and invert elevations for all rear yard and lot catchbasins
- location and ties to all valve boxes and chambers and any other relevant watermain appurtenances
- road centreline elevations
- site benchmarks
- location of all service connections to all lots and blocks
- CCTV inspection of all sewer lines including video record provided on DVD and printed report.

11.3 Materials

The Record Drawings must clearly label the installed material and shall state the name of the manufacturing company (to be indicated on a table on the drawings). Information for the following installations is required as a minimum:

- mainline storm, sanitary sewers including service tees
- sanitary and storm sewer laterals
- watermain
- watermain valves and hydrants and service valves
- manhole, valve chamber and catchbasin frames and covers
- precast concrete manholes, catchbasins and valve chambers.

11.4 Drawing Revisions

The original drawings shall be revised to incorporate all changes and variances found during the field survey and to provide ties and additional information to readily locate all underground services.

All sewer and road grades are to be recalculated to two decimal places to reflect the as-built condition.

All house numbers are to be indicated on the Record Drawings.

All street names, lot numbering and block identification(s) shall be checked against the Registered Plan and corrected as necessary.

The Record Drawing revision note(s) shall be placed on all drawings in the revision block and dated based on the date of the surveys.

The information on the Record Drawings may be checked by the Town of East Gwillimbury at any time. If any discrepancies are found, then the drawings shall be returned to the Developer's Consulting Engineer for rechecking and further revision.

The Developer's Consulting Engineer shall be required to explain in writing any major difference between the design and the "record" data and to provide verification that the alteration(s) does not adversely affect the function of the subdivision services.

Tolerances

A maximum vertical plotting tolerance of 0.2 metres on the 1:50 profile portion of the drawings and maximum horizontal plotting tolerance of 1.0 metre on the 1:500 scale drawing shall be considered acceptable without replotting.

11.5 Submission of Record Drawings

The submission of the Record Drawings on paper (one set), 3 mil mylar (one set) and electronic (AutoCAD and pdf) format must be completed before "Final Acceptance" of the subdivision will be granted by the Town of East Gwillimbury.



Town of
East Gwillimbury

SECTION D

TRANSPORTATION

Town of East Gwillimbury
Engineering Standards and Design Criteria

September 2012

SECTION D – TRANSPORTATION

12.0 ROAD CLASSIFICATIONS

All roadways in new developments shall be classified in accordance with the Town's current Official Plan which includes the following:

- Provincial Highways
- Arterial Roads
- Major Collector Roads
- Minor Collector Roads
- Rural Roads
- Local Roads

The proposed classification of all streets planned in new development areas shall be confirmed with the Town prior to the commencement of the design. Roadways within urban areas are to be designed and constructed to urban cross-sections. Roadways supporting industrial, commercial and institutional land uses are also to be built to urban design standards.

13.0 SUPPORTING TRAFFIC STUDIES

Prior to or at the time of draft plan approval, the Town will require the proponent to prepare and submit supporting traffic studies, for the Town's approval. The first portion of the study consists of a broad-based external transportation and traffic study, which will examine the property boundary conditions and interconnections with adjacent properties (including signalization issues), assessed under existing and future conditions. This Traffic Impact Study (TIS) must recommend the phasing of traffic signals and arterial road widenings to match development. The traffic study must conform to Region of York guidelines if any of the boundary roads are Region roads.

The second portion of the analysis consists of a Functional Internal Traffic Study (FITS) which balances appropriate urban design guidelines with a detailed assessment of internal transportation and traffic geometric design, on-street parking restrictions, off-street or driveway parking issues, stop sign warrants, roadway capacity and classification, lane configurations, boulevard requirements (i.e. snow storage and utility corridors), pedestrian requirements, vehicle decision making criteria and intersection vehicle sight lines. Active transportation is to be considered an integral part of this process.

The FITS will address, to the satisfaction of the Town, the compatibility of the roadway function and the adjacent proposed land uses. Specifically, appropriate building forms are required adjacent to and in the vicinity of collector/collector road and collector/arterial road intersections. The traffic study will also verify that sufficient on-

street and off-street parking can be provided without impacting driveways, safety and road operations and that appropriate accessibility standards have been complied with. The studies noted above are subject to the Town’s approval prior to final acceptance of the proposed draft plan.

14.0 GEOMETRIC DESIGN ELEMENTS

The following table summarizes the geometric design elements to be used:

Geometric Detail	Local	Minor Collector	Major Collector
Typical AADT	< 1500	1500-4000	3000-6000
Design Speed (km/hr)	60	60	70
Road Allowance Width (min.)	18	20	26
Pavement Width (m) (curb to curb)	8.6	9.8	varies
Minimum Grade (%)	0.5	0.5	0.5
Maximum Grade (%)	6	6	6
Pavement Crossfall (%)	2	2	2
Minimum Horizontal Centerline Radius (m)	90	110	160
Minimum Visibility Curves in Sag (K Values)	8	12	12
Minimum Visibility Curves on Crests (K Values)	8	15	15
Minimum Tangent Length between Reverse Horizontal Curves (m)	30	50	50
Intersection Angle (degrees)	85-95	85-95	90
Minimum Tangent Length required at stop controlled intersections – measured from centerline of road (m)	30	40	45

York Region may require greater road allowance requirements for the implementation of their policies (i.e. HOV lanes, bicycle lanes, or rapid transit).

15.0 DESIGN ELEMENTS

15.1 Typical Road Cross Sections

The typical road cross section to be used shall comply with the Urban Design Guidelines for the subdivision. Typical sections for Local, Minor Collector and Major Collector Roads are included in the Appendix to this document.

15.2 Vertical Curves

All points of grade change in excess of 1% shall be designed with vertical curves. The minimum tangent length between changes in grade, or between vertical curves shall be 9.0 m.

Combinations of vertical crests and horizontal curves are to be avoided.

15.3 Backfall at Intersecting Streets

At all street intersections the normal crossfall of the major street shall not be interrupted by the crown line of the minor street. A 1% or 2% backfall shall be provided on the minor street at all street intersections. This backfall shall continue to the end of the curb return radii on the minor street to facilitate proper drainage of the intersection.

15.4 Curb Return Radii at Intersections

The minimum curb return radius to be used for all local street intersections is 7.5 metres (this dimension does not need to be labeled on the drawings).

The curb return radii at all other street intersections shall conform to the following dimensions and shall be labeled:

Residential

Local to Local	7.5 m (as noted above)
Local to Minor Collector	9 m
Local to Major Collector	9 m
Minor Collector to Minor Collector	9 m
Minor Collector to Major Collector	9 m
Major Collector to Major Collector	15 m

15.5 Daylighting Requirements at Intersections

Daylighting at all intersection quadrants shall be included in the road allowances to provide for uniform boulevard widths. Such daylighting shall be included on the proposed plan for registration (M Plan) and on all engineering drawings. Daylighting shall conform to the following requirements:

Residential

Local to Local	5 m x 5 m
Local to Minor Collector	5 m x 5 m
Local to Major Collector	5 m x 5 m
Local to Arterial	15 m X 15 m
Minor Collector to Minor Collector	15 m x 15 m
Minor Collector to Major Collector	15 m x 15 m
Minor Collector to Arterial	15 m x 15 m
Major Collector to Arterial	15 m x 15 m

Industrial, Commercial

Local to Local	10 m x 10 m
----------------	-------------

15.6 Cul-de-sacs

Cul-de-sacs should be avoided wherever possible. When deemed appropriate by the Town they shall be constructed with a street line radius of 19.0 metres and a curb face radius of 13.0 metres. Minimum gutter grades of 0.5% shall be maintained along the flow line of the gutters around the cul-de-sac.

The maximum permissible down gradient for a cul-de-sac is 4%.

15.7 Temporary Turning Circles

Temporary turning circles will be considered whenever a road is to be continued in the future. The street line and curb radius requirements for temporary cul-de-sacs are the same as for permanent cul-de-sacs. When temporary turning circles are required within the subdivision limits, the land within the temporary right-of-way limit must be conveyed to the Town or easements must be provided in favour of the Town. The temporary turning circle is to have complete services to the street line. Signage is to be erected at the terminus of the cul-de-sac indicating that the road will be extended in the future and a dead end sign and barricade in accordance with OPSD 912.532 shall be erected.

15.8 Location of Utilities

The placement of utilities within the road allowance shall be in accordance with the Town of East Gwillimbury Standard Road Cross-Section Drawings included in the Appendix to this document.

Composite Utility Drawings shall be submitted to the Town for acceptance of the proposed utility locations.

15.9 Transit

Designs shall have consideration for transit routes including accommodations for transit facilities, and convenient pedestrian access.

15.10 Accessibility Guidelines

All roads and services within the Town are to be designed with regard for those standards being developed at the Provincial level for facilitating accessibility for persons with physical challenges. The interim and/or final guidelines are to be followed for all development work – both in the public or the private domains.

16.0 TRAFFIC CONTROLS

The proposed location and type of all street name signs, traffic control signs, signalization and pavement markings shall be shown on the Traffic Control Plan. The plan shall be prepared by a Professional Engineer skilled in municipal traffic designs and regulations. All traffic control devices, including warning and regulatory signs, street signs, parking restrictions, etc., shall conform to the Ontario Traffic Manual (OTM) and local by-laws.

16.1 Signage

All regulatory signs must be installed at the completion of the base course asphalt and maintained by the Developer until “Final Acceptance” by the Town.

The Developer will be responsible for installing all street signs and maintaining all signs in the subdivision until assumption of the subdivision by the Town with the exception of street name signs. Temporary street name signs are to be installed by the Developer prior to the first occupancy in the subdivision. Prior to final assumption the Developer will install all permanent street name signs.

16.2 Street Name Signs

Location

Street name signs shall be placed at each intersection and shall identify each street at the intersection. The location of the street name signs are shown on the Traffic Control Plan and shall be installed on common posts with the stop signs or other signs wherever possible.

Type

The street name sign blades shall be extruded aluminum having a minimum thickness of 2.3 mm, a height of 150 mm and a length of 610 to 915 mm. unless otherwise specified in Urban Design Guidelines.

The signs shall be mounted on galvanized steel U-flange posts (2.5 kg/m), 3.5 metres in length and imbedded 1.20 m into the ground, unless otherwise specified.

Lettering for the street name shall be 100 mm in height. The letters of each name/word shall be upper case. Lettering shall be white on a reflective blue background, being engineering grade reflective sheeting (Type I, ASTM).

16.3 Regulatory Traffic Control and Advisory Signage

Location

Traffic control and advisory signs shall be located in accordance with the Ontario Traffic Manual (OTM).

The speed limit for all roads under the jurisdiction of the Town of East Gwillimbury is 50 km/hr. Speed limit signs are generally not required for typical roads with a 50 km/hr speed limit. The posting of speed limit signs will only be required if necessary to address site specific issues.

Type

All regulatory signs are to be in accordance with the Ontario Traffic Manual and constructed of high intensity reflective sheeting materials (type III or IV, ASTM).

Regulatory/warning signs shall be mounted on galvanized steel U-flange posts (2.5 kg/m) and imbedded 1.20 m into the ground. Where possible, signs shall be mounted on light poles to reduce clutter in boulevards.

All signs must be erected at the completion of the base course asphalt and maintained by the Developer until "Final Assumption" by the Town. Temporary signs may be installed initially, however permanent signs are to be installed upon completion of all boulevard grading and sodding.

16.4 Pavement Markings

Pavement Markings for traffic control shall be provided and conform to the current standards of the Ontario Traffic Manual. All markings are to be completed with approved traffic paint in accordance with OPS specifications. Thermalplastic paint shall be used on any road which intersects an Arterial Road at the intersection and back to a distance of 100 metres from the Arterial Road. Approved paint in accordance with OPS specifications shall be used elsewhere.

Pavement markings shall be indicated on the plans for all stop bars, pedestrian crossing, active transportation/bike lanes, centre and lane lines, as required or directed by the Town for all subdivision streets.

Painted stop bars are required at all 4-way stops and at the intersection of any road with a road classified as a Minor Collector or higher order.

17.0 PAVEMENT DESIGN

The pavement design for all roads shall be as recommended by a qualified Geotechnical Consultant. The Geotechnical report shall be submitted as part of the Engineering Drawing Submission Package. The minimum pavement design for all streets in new subdivisions shall be as follows:

Local Road	Collector Road
40 mm HL3	40 mm HL3
50 mm HL8	80 mm HL8
150 mm Granular "A"	150 mm Granular "A"
300 mm Granular "B"	450 mm Granular "B"

All depths noted are compacted depths.

All materials shall be compacted as follows:

Item	Compaction Required (% of Standard Proctor Density)
HL3 Asphalt	Minimum 96% (Marshall Density)
HL8 Asphalt	Minimum 96% (Marshall Density)
Granular "A"	Minimum 100%
Granular "B"	Minimum 100%
Backfill	Minimum 95%
Subgrade	Minimum 98%

Granular materials to be spread and compacted in layers with a maximum depth of 200 mm.

A qualified Soils Consultant shall be engaged by the Developer to provide sampling and testing services during construction and to provide confirmation that all roads have been constructed in accordance with the design standards.

Testing and approval of all granular materials at the designated pits prior to placement and subsequent in-situ verification tests shall be performed by the Developer's Geotechnical Consultant.

Prior to the placement of asphalt pavement, the Consulting Engineer must submit the asphalt pavement mix designs to the Town for approval.

17.1 Road Sub-Drains

In general, 100 mm diameter perforated, filter cloth wrapped plastic corrugated sub-drains will be required to run continuously along both sides of all roads with curb and gutter. The sub-drains shall be trenched and have granular A bedding. The Town reserves the right to require video inspection of sub-drains.

18.0 CONCRETE CURB AND GUTTER

Concrete curb and gutter conforming to OPSD 600.040 (for single stage) or OPSD 600.070 (for two stage) shall be used on all new urban subdivision roads. Concrete strength is to be:

- minimum of 30 MPa at 28 days
- 355 kg/m³ cement
- 7% +/- 1.5% air entrainment
- 60 mm slump

Driveway depressions shall be formed in the curb according to the location shown on the engineering drawings and as detailed per OPSD 351.010. A mechanical curb cutting machine is not permitted to saw-cut driveway depressions, unless specifically approved by the Town.

All curb and gutter is to be protected from damage from heavy equipment and vehicles.

19.0 SIDEWALKS

The location requirements for sidewalks in new subdivisions shall be confirmed with the Town prior to commencing the detailed design. In general, sidewalks are required on both sides of all arterial and collector roadways and on one side of all local streets. Sidewalks may be required on both sides of roadways for roads leading to high pedestrian traffic generators such as schools and commercial uses.

Sidewalks shall be installed at locations as shown on the Typical Road Cross- Sections. The width of sidewalks for all streets shall be 1.5 m and the depth shall be a minimum thickness of 125 mm.

Sidewalk construction shall comply with OPSD 310.010 and shall be constructed on a 75mm deep compacted layer of Granular "A" bedding. Full depth expansion joints shall be installed between every third sidewalk bay. Concrete strength is to be a minimum of 30 MPa at 28 days with 7% +/- 1.5% air entrainment.

The standard sidewalk concrete thickness shall be 125 mm and increased to 150 mm at all residential driveway locations and 200 mm at all commercial and industrial driveway locations.

At street intersections the curb and the sidewalk shall be depressed to meet the roadway elevations as per OPSD 310.030.

The location of sidewalks and community mailboxes shall be coordinated to ensure that all community mailboxes have direct sidewalk access wherever practical. Prior approval from the Town will be required for any mailboxes proposed without a direct sidewalk connection.

20.0 DRIVEWAYS

20.1 Minimum Driveway Design

The minimum consolidated depth requirements for the granular base and asphalt in driveways shall be as follows:

- a) Single Family Residential
 - Asphalt 50 mm of HL3 asphalt
 - Granular 200 mm Granular "A"

- b) Commercial, Light Industrial and Apartments
 - Asphalt 40 mm HL3 surface course
50 mm HL8 base course
 - Granular 150 mm Granular "A"
225 mm Granular "B"

- c) Heavy Industrial Driveways
 - Asphalt 40 mm HL3 surface course
75 mm HL8 base course
 - Granular 150 mm Granular "A"
300 mm Granular "B"

20.2 Driveway Grades

The maximum permissible design grade for any driveway on private lands shall be 6% (desirable), or 8% (maximum). The minimum grade for all driveways shall be 1%. Negative sloping driveways are not permitted.

20.3 Driveway Depressions

The minimum width of any driveway shall be 2.5 m with the maximum width governed by the Town's Zoning By-law. Curb depressions shall extend 0.3 m beyond each side of the driveway. A minimum 0.3 m separation at the curb (measured from full curb prior to curb depression) shall be provided between driveways within cul-de-sacs and elbows along with corner lots and lots abutting walkways.

20.4 Walkways

Walkways are to be constructed with concrete sidewalks on a compacted base, as per the standards for sidewalks and as shown in the Town of East Gwillimbury Parks Design Standards Manual.

In special cases where the major system (i.e. overland) stormwater flows are to be conveyed through walkways, a walkway with curbs shall be used. The hydraulic capacity of the walkway as noted in the graph below is not to be exceeded.

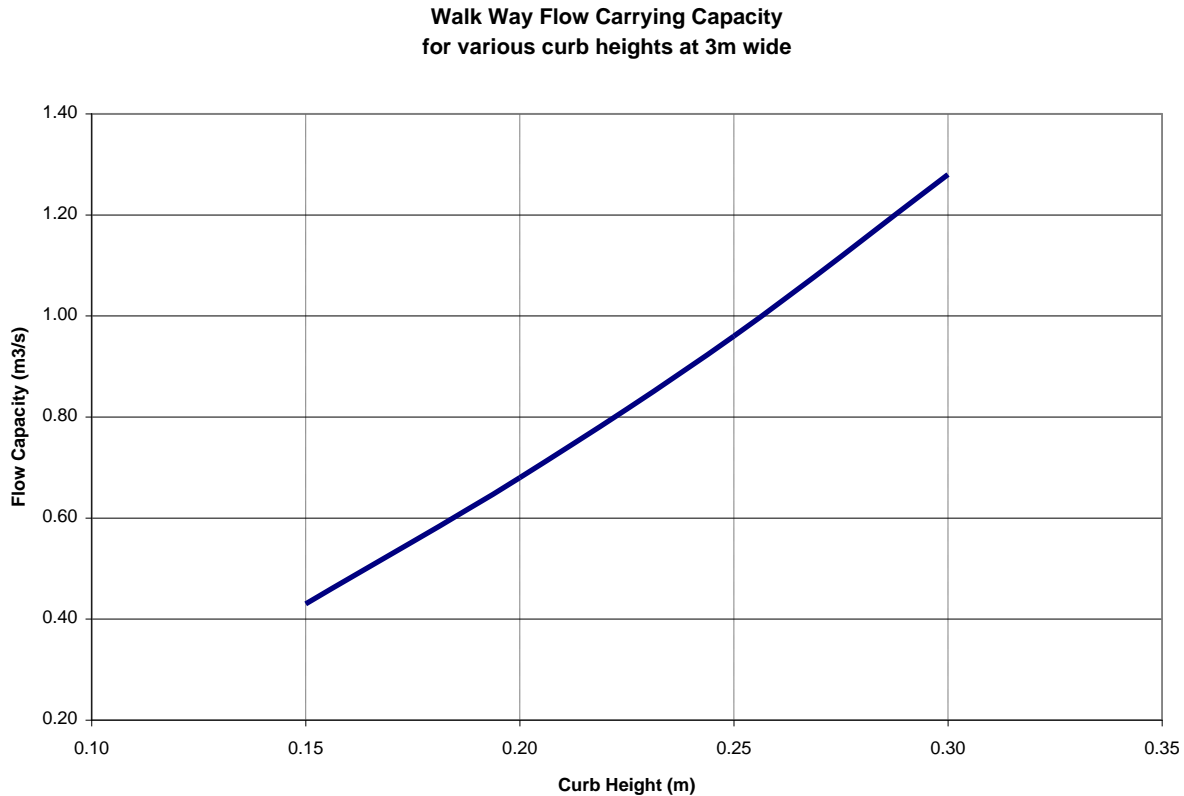

21.0 BOULEVARDS

All boulevard areas are to be graded according to the details shown on the Town’s standard drawings and to the satisfaction of the Town. The final grade of the sod shall match the finished grade of the top of the concrete curb and sidewalk.

All debris and construction materials shall be removed from the boulevard area upon completion of the base course asphalt and shall be maintained in a clean state until the roadway section is completed.

Clean, weed free topsoil shall be placed on all boulevard areas that are to be sodded. The minimum depth of topsoil shall be 150 mm.

No. 1 Nursery Sod shall be used for all areas that are to be sodded.

21.1 Placing of Final Surface Course Asphalt

The placement of surface course asphalt shall not commence in any area until all of the following conditions are met:

- a) a minimum period of one (1) year has expired from the completion date for the placement of the base course asphalt
- b) 85% of the dwellings have received Final Occupancy Permits
- c) all undeveloped lots are rough graded in accordance with the current and accepted lot grading plans
- d) all service connections for multiple family commercial, institutional or other blocks are installed
- e) the approval of the Town is obtained in writing
- f) all deficiencies and settlements have been repaired
- g) favourable weather conditions are present, as defined by OPS 310 specifications.



Town of
East Gwillimbury

SECTION E

LOT GRADING

Town of East Gwillimbury
Engineering Standards and Design Criteria

September 2012

SECTION E – LOT GRADING

22.0 GENERAL

These guidelines are provided for guidance in the preparation of drainage plans. Since they are only guidelines, they cannot cover each and every situation that may be encountered in the field. Direct consultation should be made with the Town's General Manager of Community Programs and Infrastructure or Designate when the Drainage Plan Designer feels that deviation from these guidelines is warranted.

It is imperative that the overall initial Draft Plan of Subdivision be laid out with regard to the lot grading criteria outlined in this section. In particular lots requiring rear yard drainage swales may require extra depth than the adjacent lots to the rear to allow adequate space to create a rear yard amenity area as outlined in this section.

The approval of a Drainage Plan is related to drainage only. It is the responsibility of the Developer's Engineering and Planning Team to ensure that the Drainage Plan compliments the land and suits the house to be constructed.

22.1 Objectives

- All areas shall be graded in such a way as to provide proper positive drainage.
- Grading shall be performed in such a way as to preserve existing trees wherever possible, both in development areas and on adjacent lands.
- Drainage flows must be directed away from houses.
- Storm drainage is to be directed to approved outlets on public lands and shall not adversely affect adjacent lands.
- The use of rear lot catchbasins and retaining walls should be minimized.

23.0 LOT GRADING CRITERIA

23.1 Type of Drainage Pattern

- Back to front drainage is desirable in instances where drainage contributing to each side yard swale is restricted to the lots directly adjacent to the swale and no external flows or flow from the rear yards of neighboring lots is captured by the side yard swale.
- Split lot drainage with rear yard catchbasins is required where difficulties in providing side yard swales are encountered.
- Rear yards which drain through abutting lower back-to-front type lots are permitted where:

- sufficient fall is available between the adjacent streets to achieve desired grades for swales and yards as per the criteria outlined in this section
- the drainage from the upstream lot is limited such that a minimum of 50% of the roof area of the upstream lot drains to the front yard.
- Walkout, back split and front split lots will be permitted where required due to topography constraints. In all cases the grade differential between the front and rear yard specified house grade shall be governed by the sloping required along the side of the building envelope. Grades shall vary from a minimum 2% to a maximum 4:1 slope and shall be confined to the building side yard area. Lots with a front to rear yard grade differential exceeding 2.5 metres are considered extraordinary and will require specific approval from the Town and may require advisory clauses to be inserted into Purchase and Sale Agreements of all perspective Purchasers.
- In determining maximum permissible grade differential between front and rear property line elevations compatibility of house types and impact on adjacent homes will be considered by the Town. While these standards do not set out maximum allowable grade differentials the Town will limit the grade differential on a site specific basis based on the particular circumstances unique to each subdivision.

23.2 Specified House Grade (SHG)

The specified house grade, or building envelope grade, represents the highest lot elevation adjacent to the proposed building. This elevation shall be a minimum of 0.15 m above invert of the highest swale adjacent to the building. Top of foundation for any building will be a minimum of 0.15 m above the specified house grade.

A minimum separation of 150 mm shall be provided between brickline and the final ground elevation of all houses. This shall be increased to a minimum of 200 mm for any moisture affected material.

The following criteria shall apply to detached and semi-detached units:

- Rear to Front Lot Drainage – The SHG for this type of lot grading will be based on the highest apron swale invert (swale breakpoint) at the rear of the building.
- Split Drainage – The SHG for this type of lot grading will be based on the highest side yard swale invert (swale breakpoint) adjacent to the building.
- Backsplit, Walkout and Front Walkout Drainage – The SHG for this type of lot grading will be noted for the front and rear of the building. The SHG will be based on the highest side yard swale invert (swale breakpoint) adjacent to the building.
- Reduced Setback Lots – The SHG for lots with reduced setbacks should be reviewed by the Designer to ensure lot grading meets the intent of Town Standards and sound design practices. The methods identified above for

determining SHG elevations may not apply to reduced setback lots and other non-conventional lot types. The Designer will be required to determine the most appropriate SHG for the lot type and may be required to supply detailed grading plans for individual lots considered by the Town to be non-conventional.

The following criteria shall apply to on-street townhouses:

- End Units – The SHG will be based on the criteria noted above for detached and semi-detached units.
- Interior Houses – SHG will be the highest exterior elevation adjacent to the unit, and will be a minimum of 0.15m above an adjacent swale, or a minimum of 2.0% above the streetline or lot line elevation.
- Units with common driveways to have the same SHG based on the higher SHG calculated on the basis of the above criteria.
- Grade separation between SHG's to be taken up externally with 3:1 minimum embankment or approved retaining wall construction.
- Split or walk-out house types, front and back SHG's to be established using applicable criteria above.
- Number of units at same SHG shall be as per the following:
 - On road grades of under 2% - no more than four (4) units
 - On road grades of 2% to 4% - no more than two (2) units
 - On road grades of over 4% - each unit is considered individually.
- Retaining walls must be used where difference in SHG elevations exceeds 0.5 metre between interior units.

23.3 Slopes

- The grade difference in the rear yard shall be taken up by the use of two types of slopes:
 - slopes with a gradient between 2% and 5% which is considered “usable area”
 - slopes not greater than three parts horizontal to one part vertical (3:1) to a maximum height of 1.0 metre. Slopes not greater than four parts horizontal to one part vertical (4:1) shall be used for heights greater than 1.0 metre
- Rear yards shall be graded such that minimum of 6.0 metres is to be sufficiently level (2% to 5% slope). This shall be considered to be the rear lot “useable area”.
- The maximum permissible grade along rear lot line between lot corners shall not exceed 6%.

- Yard surfaces shall have a minimum slope of 2%. Yard surfaces shall have a maximum slope of 3:1 to a maximum vertical grade differential of 1.0 metre and 4:1 if the vertical grade differential exceeds 1.0 metre.
- A 1.0 metre wide flat area is required between 3:1 or 4:1 downward slopes and any property line.
- The minimum slope on driveways shall be 2%. The maximum slope on driveways shall be 8%.
- All lots shall have a 0.6 metre wide unobstructed path draining at a 2% slope away from the house along at least one side of the house. This stipulation is in addition to the 150 mm apron required around buildings and is needed to permit the construction of a walkway to the rear of the house.
- An undisturbed flat area having a width of 0.5 metres shall be provided at the boundary limits adjacent to other properties, in order that the existing boundary elevations shall be maintained. No filling up to or upon private lands shall be tolerated unless written permission is obtained from the adjacent Owner. Where two developments are concurrently underway, the common boundary elevations are to be established to mutually beneficial elevations, agreed to by each party.

23.4 Swales

- Swales shall have a minimum grade of 2% and maximum side slopes of 3:1.
- Swales shall range in depth from a minimum of 150 mm to a maximum of 450 mm.
- Swales parallel to the rear lot lines shall be located at a distance based on the depth of swale but under no circumstances will the invert of the swale be permitted to be located more than 1.0 metre from the rear lot line.
- Drainage flows which are carried around houses are to be confined in defined swales located as far from the house as possible. The depth of these swales should be kept as close as possible to the minimum of 150 mm.
- The maximum flow allowable in a side yard swale shall be that from three (3) backyards or 750 m², whichever is less.
- Rear Yard Swales
 - the maximum length of a rear yard swale shall not exceed 60 metres
 - the maximum area contributing to the rear yard swale shall be 2000 m².

23.5 Rear Lot Catchbasins

- All rear lot catchbasin grates are to be as per the standard drawing included in the Appendix to this document. The centerline of the catchbasin top is to be 1.2

metre from the rear lot line. The catchbasin frame to be set at the elevation of the invert of the lowest swale.

- Rear yard catchbasin leads shall be a minimum diameter of 250 mm. The leads shall be encased in concrete from the catchbasin to the street line.
- All catchbasin leads are to be located a minimum of 0.6 metres from lot line; catchbasin leads to be constructed on one lot. All catchbasin leads are to be on easements having a minimum width of 3.0 metres. The use of “hour glass” easements will be permitted in instances where 3.0 metre widths are not achievable between houses.
- Rear lot catchbasin leads shall be connected directly to manholes whenever possible. The layout of the storm sewer shall have consideration to this requirement to maximize the number of RLCB leads which can connect directly to manholes.
- When rear lot catchbasins are required the Designer must consider the impacts that a plugged catchbasin will have with respect to flooding depth and area which will be impacted. The grading design must incorporate allowance for relief outlets in the event that plugging does occur.

23.6 Sodding and Ground Cover Requirements

- Lots (including drainage ditches or swales) are to be completely topsoiled and sodded with 150 mm of topsoil and No. 1 Nursery Sod.
- Clear stone (19 mm gradation) at a minimum depth of 100 mm may be placed in side yard areas between houses with a distance less than 2.0 metres instead of sod. A transition run-out area to drain the sub-grade shall be provided at the clear stone/sod interface. This shall be detailed on the grading plans.

24.0 RETAINING WALLS

The lot grading design must minimize and ideally eliminate the need for retaining walls. In carrying out the grading design the Designer should not assume that retaining walls will be permitted by the Town. Specific permission from the Town will be required for any retaining walls being proposed. All reasonable alternatives must be investigated prior to the Town being in a position to consider allowing the use of retaining walls.

Where retaining walls are required they shall be constructed of precast concrete. No wood retaining walls will be permitted. All retaining walls, regardless of height, must be designed by a Professional Engineer. Certification from a Professional Engineer will be required for each wall constructed clearly stating that the wall has been designed to suit the site conditions, that construction of the wall has been inspected by the Engineer and that it has been constructed in accordance with the design.

25.0 LOT GRADING CERTIFICATION

Prior to Assumption for any aboveground works in the subdivision the Developer's Engineering Consultant will be required to submit a Lot Grading Certificate for every lot. If retaining walls have been constructed on any lot an additional Certificate will be required for each lot with retaining walls.

The "Template" Lot Grading Certificate and Retaining Wall Certificate included herein shall be used and no substitutions in wording will be accepted.

LOT GRADING CERTIFICATION FORM

Town of East Gwillimbury

Subdivision: _____ Municipal Address: _____

Registered Plan Number: _____ Lot Number: _____

Plot Plan Approval Date: _____

I hereby certify that I (or a competent representative from this firm on my behalf) have inspected the above noted lot and that:

- the grading generally conforms with that shown on the Approved Plot Plan and Overall Grading Plan for the Subdivision
- the minimum of 150 mm of quality topsoil has been placed and the lot has been sodded in accordance with Town Standards
- all valves are operational and adjusted to the finished ground level
- the Ontario Building Code requirements are satisfied with regard to the required finished ground level relative to the exterior foundation wall of the house
- all downspout elbows are a maximum of 100 mm above splash pads
- retaining walls (check one box) no retaining walls are constructed or required on this lot
 retaining wall certification is attached

This certification is based upon our field investigation which was carried out on _____

Seal and Signature of Developer's Consulting Engineer

Date: _____

This Section to be Completed by the Town's Representative

Date Received: _____

Certificate Reviewed By: _____

On-Site Inspection Carried Out By: _____ (Optional)

Date: _____

Notes:

RETAINING WALL CERTIFICATION FORM

Town of East Gwillimbury

Subdivision: _____ Municipal Address: _____

Registered Plan Number: _____ Lot Number: _____

Plot Plan Approval Date: _____

I hereby certify that the retaining wall(s) constructed on the above noted lot have been designed to my satisfaction using sound engineering principles, have been inspected by me (or a competent representative on my behalf) and have been constructed in accordance with the design.

Guards have been constructed (where necessary) in accordance with the requirements of the Ontario Building Code.

Seal and Signature of Developer's Consulting Engineer

Date: _____

This Section to be Completed by the Town's Representative

Date Received: _____

Certificate Reviewed By: _____

On-Site Inspection Carried Out By: _____ (Optional)

Date: _____

Notes:



Town of
East Gwillimbury

SECTION F

SANITARY SEWERS AND APPURTENANCES

Town of East Gwillimbury
Engineering Standards and Design Criteria

September 2012

SECTION F – SANITARY SEWERS AND APPURTENANCES

26.0 HYDRAULIC DESIGN

26.1 Confirmation of Capacity

Prior to commencement of any design for sanitary sewage works within the Town, the Developer's Consulting Engineer shall contact the municipality to ensure that adequate external trunk sewer and treatment plant capacity is available for the proposed development.

26.2 Sanitary Drainage Plan

The sanitary drainage plan shall be prepared to a scale suitable to show all the tributary areas that are being used to determine the design flows.

The design flow in each manhole and length of sewer shall be computed on standard sanitary design sheets. A typical Town of East Gwillimbury Design Sheet is included in the Appendix to this document. For each area entered on the design sheet, the manhole numbers, size, grade and material of the sewers and the numbers consistent with the detailed plan and profile for each section of the sanitary sewer shall be shown.

Calculations for the sizing of all sewers shall be carried out on the Town of East Gwillimbury Design Sheet which is included in the design standards document.

26.3 Calculation of Sewage Flows

All sewers are to be designed for maximum design flow plus an infiltration allowance.

Peak domestic sewage flows are to be calculated using the following formula:

$$Q(d) = \frac{PqM}{86,400} + IA$$

Where,

Q(d) = Peak domestic sewage flows (including extraneous flows in L/s)

P = Design population

q = Average daily per capita domestic flow in L/cap/day
(exclusive of extraneous flows)

M = Peaking factor

I = Unit of peak extraneous (infiltration) flows in L/ha/s

A = Gross tributary area in hectares

For **Residential Development** the peaking factor shall be calculated based on the Harmon Formula:

$$M_d = 1 + \frac{14}{4+P^{0.5}}$$

Where,

P = Population, in thousands

M_d (Maximum) = 4.0

M_d (Minimum) = 2.0

For **Industrial Development** the peaking factor shall be calculated as follows:

$$M_i = 6.6604 \times \text{Area}^{-0.1992}$$

Where,

M_i = industrial peaking factor

A = gross lot area (ha)

26.4 Average Daily Flows

The following average daily flows are to be used in calculating the design flows for sewer sizing:

Residential	=	350 L/c/d
Industrial	=	35,000 L/ha/d
Commercial	=	28,000 L/ha/d
Institutional	=	18,000 L/ha/d

26.5 Extraneous Flows

An infiltration allowance of 0.286 L/sec/ha shall be used in determining the design flows. The Town requires all sewers to be constructed to achieve a reduction of infiltration to zero allowable. All sewers will be tested in accordance with York Region's Sanitary Sewer Commissioning Guidelines.

26.6 Design Populations

The design population for residential developments shall be derived using the proposed Plan of Subdivision and the following densities:

Single Detached Dwellings	=	3.36 ppu
Semi-Detached Dwellings	=	3.36 ppu
Townhouses	=	2.78 ppu
Apartments	=	1.76 ppu

In the absence of a proposed Plan of Subdivision, populations should be estimated based on drainage areas and the land uses identified in the Town’s Official Plan or Master Servicing Studies.

An average population of 50 persons/ha shall be used for all employment areas.

27.0 SANITARY SEWER DESIGN

27.1 Location

All sanitary sewers shall be located as shown on the Standard Road Cross-Section. The standard location shall generally be 1.5 m offset from the centerline of the road allowance.

All sanitary sewers are to have a minimum horizontal separation of 2.5 m and a vertical clearance of 0.5 m from watermains in accordance with MOE Regulations.

27.2 Pipe Capacities

Manning’s formula shall be used in determining the capacity of sewers.

$$Q = \frac{1000AR^{2/3}S^{1/2}}{n} \quad V = \frac{R^{2/3}S^{1/2}}{n}$$

Where “Q” is in litres/second, “V” is in metres/second, “R” is in metres, “S” is in metres/metre, and “A” is in square metres.

The roughness coefficient “n” shall be 0.013 for all types of sewers.

The table below provides the allowable sanitary sewer capacities and gradients. This table shall be used to determine the maximum and minimum slopes for sanitary sewers. Although the Manning’s Formula is to be used as a basis for sewer design, the values listed in the table will supersede the results of Manning’s calculations, where applicable. In the case of partial pipe flow, the actual velocity is to be checked against the minimum allowable velocity at the design flow rate.

Allowable Sanitary Sewer Capacities and Gradients

Diameter (mm)	Q Max (m ³ /s)	Slope Min (%)	Slope Critical (%)	Slope Max (%)
200	0.042	0.50	1.54	8.2
250	0.074	0.50	1.43	6.1
300	0.12	0.50	1.34	4.8
375	0.20	0.50	1.25	3.5
450	0.32	0.50	1.17	2.8

Flow Velocities

Minimum acceptable velocity = 0.6 m/s

Maximum acceptable velocity = 3.0 m/s

27.3 Minimum Size

The minimum allowable size for a sanitary sewer shall be 200 mm in diameter.

27.4 Minimum and Maximum Grades

The absolute minimum and maximum grades for sanitary sewers shall be in accordance with the table included in Section 27.2 subject to achieving minimum acceptable velocity at the design flow. The minimum grade for the first upstream leg shall not be less than 1.0%. The maximum grade for the first upstream leg shall not be greater than 2.0% unless the sewer is to be extended in the future.

27.5 Minimum and Maximum Depths

The depth of the sewer shall be measured from the final centreline finished road elevation to the top of the sanitary sewer. The minimum depths of sewers for residential areas shall be 2.7 m.

The maximum depth of sewers with direct lateral connections shall be 8.0 m (measured from finished centerline of road elevation to invert of sewer). In cases where deeper sewers are required these shall be considered trunk sewers and no direct lateral connections will be permitted. Separate local sewers constructed above the trunk sewers will be required for connection of laterals. Manholes are to be common wherever possible with drop structures.

27.6 Curved Sewers

The use of radius pipe or deflected pipe is not permitted.

27.7 Termination Points

All sewers shall be terminated at the subdivision limits when external service areas are being considered in the design with suitable provision in the design of the terminal manholes to allow for future extension of the sewer.

27.8 Pipe Crossings

A minimum clearance of 75 mm shall be provided between the outside of the pipe barrel at the point of crossing for storm and sanitary sewers. A minimum clearance of 0.5 m shall be provided for all sewer and watermain crossings.

In the event the minimum clearances cannot be obtained, the designs must adhere to MOE policies. In addition the pipes shall be concrete encased to ensure that the pipes are properly bedded.

27.9 Changes in Pipe Size

No decrease of pipe size from a larger upstream to a smaller downstream will be allowed regardless of the increase in grade.

27.10 Pipe Bedding

The class of pipe and the type of bedding shall be selected to suit loading and proposed construction conditions. Details and types of bedding and backfill are illustrated in OPSD 802.010 and 802.030. The width of the trench at the top of the pipe must be carefully controlled to ensure that the maximum trench width is not exceeded unless a higher class of bedding or higher strength pipe is used. The recommendations of a Geotechnical Engineer will be required in determining strength of pipe required and construction methods to be used.

28.0 MANHOLES

28.1 Location

Manholes shall be constructed at the following locations:

- at changes in pipe size
- at pipe junctions
- at changes in pipe slope
- at changes in pipe alignment
- at changes of pipe material (example: PVC to concrete)
- at intermediate intervals as per Section 28.2.

The outside wall of any manhole structure located within the roadway shall not be located closer than 1.5 m to a curb. The manholes shall be oriented in such a way that the access cover is offset towards the centerline of the road.

28.2 Maximum Spacing

The maximum spacing between manholes is 100 m.

28.3 Manhole Types

Manholes shall be constructed of pre-cast concrete with monolithic base and pre-benched sealed couplings for all pipes.

The Ontario Provincial Standard (OPS) manhole details shall be used for manhole design, where applicable. In all cases where the standard drawings are not applicable, the manholes shall be individually designed and detailed.

A reference shall be made on all profile drawings to indicate the type and size of all sanitary manholes.

Pre-cast manholes shall conform to ASTM Specification C478 latest revision.

28.4 Manhole Frame and Covers

Manhole covers shall be the “closed” type per OPSD 401.010 and shall be embossed with the word “Sanitary”.

All manholes constructed in the vicinity of low points or outside of the paved roadway shall have watertight covers. In addition all manholes located in cul-de-sacs shall have watertight covers.

All manholes located within the travelled portion of the roadway shall have the rim elevation initially set flush with the base course asphalt. A maximum of 300 mm height of modular rings shall be permitted on all manholes in new subdivisions.

Prior to the placement of the final course asphalt, the manhole frame shall be adjusted to suit the final surface asphalt elevation.

28.5 Head Losses

The minimum drop for inverts in any manhole shall be 0.050 m for sewers turning 45° or less and 0.100 m for any sewer turning 90°. The maximum change in direction permitted for any sewer is 90° (ie. No acute angle turns will be permitted). Minimum drops in accordance with MOE policies will be considered in extreme situations where approved by the Town.

In order to reduce the amount of drop required, the Designer shall, wherever possible, restrict the change in velocity between the inlet and outlet to 0.6 m/s.

Hydraulic calculations shall be submitted for all junction and transition manholes on sewers where there is a change in velocity of greater than 0.6 m/s is proposed. In addition, hydraulic calculations may be required for manholes where in the opinion of the Town, there is insufficient invert drop provided across any manhole.

Regardless of the invert drop across a manhole, as required by calculations, the obvert of the outlet pipe shall not be higher than the obvert of the inlet pipes at any manhole location.

28.6 Manhole Design

- All manhole access openings shall be located on the side of the manhole parallel to the flow for straight run manholes, or on the upstream side of the manhole at all junctions.
- The manhole shall be centered on the sanitary sewer main.
- The maximum change in the direction of flow in any sanitary sewer manhole shall be no more than 90 degrees. A change of flow direction at acute interior angles will not be permitted.
- All sanitary manholes shall have monolithic prebenched bases to the obvert of the pipe with premanufactured connections.
- Safety gratings shall be required in all manholes in accordance with OPS Specifications. Where practical, a safety grating shall be located 0.5 m below the drop structure inlet pipe.

28.7 Drop Structures

Drop structures shall be used when invert levels of inlet and outlet sewers differ by 0.9 m or more. Wherever feasible, sewer systems should be designed to avoid the use of drop structures. Internal drop structures are not permitted. Precast drop structures are permitted. All drop structures shall be constructed in accordance with OPSD 1003.020.

29.0 SANITARY SERVICE CONNECTIONS

29.1 General

All sanitary sewer connections for single, semi-detached and townhouse lots shall be made with single service pipes and shall conform to Ontario Provincial Specifications. All connections are to have a watertight PVC test fitting installed at the property line. The sewer connection shall extend 1.5 m inside of the property line and terminate with a watertight plug. The pipe is to be green in colour and marked with a 50 mm x 100 mm x 2.4 m stake painted green.

29.2 Location

The proposed location of the sanitary sewer service shall be shown on the Plan and Profile Drawings and Composite Utility Plans. The location shall be as per the standard drawing included in the Appendix to this document.

29.3 Size

Service connections for single family and semi-detached (or linked) units shall be 125 mm in diameter.

Service connections for multiple family blocks, commercial, institutional and industrial areas shall be sized according to the intended use.

29.4 Connection to Main

The connection to the main sewer shall be made with an approved manufactured tee. Approved saddles shall be used for connecting to existing sewer mains.

Connection to manholes will be allowed only if the invert is connected no higher than the obvert of the outlet pipe in the manhole and properly benched.

No service connection of a size greater than half the diameter of the main shall be cut into the main sewer. A manhole shall be installed on the main sewer at the intersection of a service connection which has a size greater than half the diameter of the main sewer except as provided below.

A 125 mm or 150 mm service connection will be permitted to connect to a 200 mm and 250 mm main sewer provided an approved manufactured tee is installed and provided the invert of the service connection is above the spring-line of the main sewer.

29.5 Depth

The depth of the service connections for single family units, semi-detached units and townhouses at the property line measured from the finished centre line road elevation shall be:

- Minimum – 2.50 m
- Maximum – 3.00 m (unless proposed house types require deeper service depths)

Risers shall be used when the obvert depth of the sewer main exceeds 4.50 m. The riser section shall be brought to a depth of within 2.7 m of centerline road grade. Controlled settlement joints shall be provided for all risers.

29.6 Grades

Size of Pipe	Minimum Grade	Maximum Grade
125 mm	2%	8%
150 mm	1%	6%

29.7 Connection to Multiple Family and Other Blocks

An inspection manhole is required on private property located 1.50 m from the property line to the centre of the frame and cover on all connections to multiple family and other blocks.

29.8 Connection to Commercial/Industrial Institutional Blocks

An inspection manhole is required on private property located 1.50 m from the property line to the centre of the frame and cover.

29.9 Connection to Park Blocks

An inspection manhole is required on the park block located 1.50 m from the property line to the centre of the frame and cover.

30.0 PIPE MATERIALS

A list of acceptable pipe materials is included in the Appendix to this document.

31.0 SANITARY PUMPING STATIONS

Sanitary pumping stations shall be constructed to the most recent Town Standards and Requirements. All pumping stations shall provide bypass pumping, external electric power supply and internal alternate fuel source (natural gas or diesel). Pumping stations shall meet all Region of York and MOE Standards.



Town of
East Gwillimbury

SECTION G

STORM DRAINAGE
&
STORMWATER MANAGEMENT

Town of East Gwillimbury
Engineering Standards and Design Criteria

September 2012

SECTION G – STORM DRAINAGE & STORMWATER MANAGEMENT

32.0 STORM DRAINAGE POLICIES

This section outlines the policies, design criteria and applicable parameters for the design and implementation of storm drainage facilities within the Town of East Gwillimbury. These policies are to be adhered to in the design of all stormwater management facilities, including sewers, surface drainage and related environmental facilities.

32.1 Planning, Policies and Design Criteria

The most current version of the following Ministry of the Environment (MOE), and Lake Simcoe Region Conservation Authority (LSRCA) guidelines, policies and standards, apply to the design of storm drainage facilities in the Town of East Gwillimbury (Town).

- Ministry of the Environment (i.e. Stormwater Management Planning and Design Manual, March 2003)
- Lake Simcoe Region Conservation Authority Watershed Development Policies (approved November 2008).

Development proponents are also required to confirm design criteria and obtain approvals from any other relevant ministries or agencies (i.e. Ministry of Transportation, Ministry of Natural Resources, Department of Fisheries and Oceans, etc.).

The planning and design of stormwater management (SWM) facilities shall be discussed with the Town and the LSRCA early in the planning process and shall focus on minimizing the number of pond facilities. Individual on-site SWM facilities are discouraged. Water quality and quantity control in new development areas are to be provided in Town-owned municipal blocks. In the case of infilling proposals, on-site SWM concepts may be considered by the Town in conjunction with any potential off-site storm drainage improvements.

The planning and design of each pond shall also focus on opportunities to integrate the pond with the surrounding topography and land uses. Ponds are to be created as public amenity features and are to be safe, significantly visible and accessible to the general public. Opportunities for linkages through the use of trails to parks, larger open space, floodplain areas or other SWM facilities are to be maximized.

The planning and design of SWM works is to have full regard for riparian rights of both upstream and downstream Landowners. Any change in flow rates, or water levels that would occur as a result of the development, SWM drainage areas and/or in-stream works to neighbouring private properties must be adequately addressed. Written permission from affected Landowners must be sought in cases where acknowledged impacts are proposed and any governing legislation, in this regard, must be strictly followed.

32.2 Levels of Service

The level of service to be provided by the storm drainage system is listed in the table below unless stipulated otherwise. The planning of access routes for emergency services (i.e. police, fire, ambulance) may result in higher levels of service as determined by the Town.

Levels of Service for Major and Minor Systems

Item	Level of Service	Comments
Storm Sewers	1:5 year storm	<ul style="list-style-type: none"> catchbasin density such that sewers capture and convey the 1:5 year storm, while minimizing flow on streets
Hydraulic Gradeline	1:100 year storm	<ul style="list-style-type: none"> no closer than 0.5 m between 1:100 year storm hydraulic gradeline and finished basement floor elevations
Foundation Drain Collector	Greater of 1:100 year or Regional Storm	<ul style="list-style-type: none"> not susceptible to backwater or surcharging
Major System	1:100 year storm	<ul style="list-style-type: none"> large drainage areas may require classification as a floodplain using regulatory storm criteria (LSRCA) overland flow cannot exceed width or flow capacity of right-of-way
Stormwater Management	1:100 year storm	<ul style="list-style-type: none"> unless otherwise directed by Town
Critical Infrastructure	Regional Storm or Greater	<ul style="list-style-type: none"> very special cases to be specified at the discretion of the Town

Storm sewers are to be initially sized for the 1:5 year storm. The Town of East Gwillimbury Storm Sewer Design Sheet is included in the Appendix. Subsequent hydraulic gradeline analyses and stormwater management may increase sewer sizes and/or require catchbasin inlet controls to be used.

32.3 Hydrology and Hydrologic Modelling

The estimation of peak design flow rates can be done using the Modified Rational Method or computer model simulation. The Modified Rational Method should be used to design storm sewers and estimate peak flow rates from small urban areas. Computer analyses are best suited to large urban areas, rural areas and designing municipal SWM facilities.

The minimum and maximum duration of design storms are 4 hours and 24 hours respectively. Hyetographs of the design storms selected by the Town (distribution based on the Toronto-Pearson data and a 10 minute discretization) are provided in the Appendix to this document for the following storms:

- 24 hour SCS (Type II)
- 4 hour Chicago distribution

- 24 hour Chicago distribution (where requested).

The Town or LSRCA may request other design storm lengths and distributions for evaluation during the pre-consultation process.

Rainfall IDF curves to be used as defined by the equation:

$$I = a \times (b+t)^{-c}$$

Where:

I = Rainfall intensity (mm/hr)

t = Time of Concentration (minutes)

The coefficients for a, b and c values are shown below:

Return Period	a	b	c
Pond Bypass	160	4	0.800
1:2 year	648	4	0.784
1:5 year	930	4	0.798
1:10 year	1021	3	0.787
1:25 year	1100	2	0.776
1:50 year	1488	3	0.803
1:100 year	1770	4	0.820

33.0 STORMWATER MANAGEMENT POND DESIGN

Stormwater management ponds are required to meet provincial SWM prerequisites as set out by MNR, MOE or LSRCA.

SWM pond locations, functions and design criteria shall be confirmed through consultation with the Conservation Authority and the Town. Where Stormwater Master Plans have been completed, the design criteria shall follow the approved Master Plan. End-of-pipe facilities are acceptable to the Town when the designs are safe, maintainable, integrated with the surrounding landscape, and aesthetically pleasing.

The Town concedes the overall design requirements to the most recent provincial direction, as is acceptable to the LSRCA. Exceptions to this are in circumstances that involve:

- matters of public safety and aesthetics
- operation and maintenance requirements
- protecting the riparian rights of private Landowners
- protection of municipal infrastructure
- conflicts with land use.

In these cases, the Town may invoke additional release rate stipulations and design requirements over and above those required by other agencies.

The Town requires integration of stormwater management pond grading design with the surrounding landscape. Where possible SWM ponds are to be integrated with parks and open space systems. The design is to consist of varied contour grading to ensure public safety, provide improved aesthetics, support of a variety of plantings and vegetation and provide passive recreational activities (i.e. walking trails, bike paths, vistas, etc.). Safety aspects must be given special consideration. This includes identifying the use of gentle slopes in areas where passive recreation takes place, increasing density of appropriate plantings and vegetation on steeper slopes, handrails/guardrails at headwalls and placing signs which inform of the function and potential hazards of SWM ponds.

Subject	Criteria
Side Slopes	<ul style="list-style-type: none"> • Maximum permissible side sloping is 4:1. • 3:1 slopes will be considered above the 1:100 year water level only in situations with extenuating circumstances. • A safety shelf with maximum 7:1 side slopes is required for at least 3.5 m (plan view), on either side of the Normal Water Level (NWL). • A minimum 3 m wide strip at a maximum crossfall of 4% is to be provided around the property boundary of the SWM block for the purposes of grass cutting. • A horizontal terrace of 3.0 m required for continuous slope changes in elevation greater than 3.0 m. • Berming of wet ponds are to be designed as proper dams (clay core, toe drains, etc.).
Depths	<ul style="list-style-type: none"> • Maximum permanent pool depth – 2.5 m. • Maximum water level fluctuation – 2.0 m (active storage area). • Minimum freeboard – 0.25 m.
Outlets	<ul style="list-style-type: none"> • A bottom draw low flow outlet structure with reverse sloped control pipe is required for the extended detention outflow. • A minimum orifice size of 75 mm diameter is permitted to avoid clogging issues. • Emergency overflow with spill capacity for the Regional Storm Event is required. In lieu of modeling the Regional Storm Event, the peak overflow can be estimated by assuming 0.1 m³/s/ha of drainage area. Where public safety or severe property damage may be at risk arising from dam failure, the Town may ask for the emergency overflow to convey more than 0.1 m³/s/ha. • Safety grates shall be provided on all storm sewer inlet and outlet pipes and safety railings shall be provided along the top of all headwalls 600 mm in height or greater.
Landscaping	<ul style="list-style-type: none"> • Suitable landscape plantings are required to discourage access, break accidental falls, and to provide for both aesthetics and environmental enhancement, and are subject to the requirements of the Town of East Gwillimbury.
Fencing	<ul style="list-style-type: none"> • The Town prefers not to unnecessarily require fencing around pond blocks, but instead, allow for casual public access to facilities, subject to maintaining public safety. • Fencing is required along the limit of lots adjacent to SWM facilities. • Specific approval will be required from the Town for consideration of fenced facilities. • Where approval for fencing SWM ponds is given by the Town, 1.8 m high black vinyl-coated fencing, posts and hardware shall be used.
Signage	<ul style="list-style-type: none"> • Signage to educate and advise public of facility must be erected.

33.1 Operational and Maintenance Features

The SWM pond designs are to incorporate features that allow the Town to operate and maintain the facility. These features include:

Subject	Criteria
Access Road	<ul style="list-style-type: none"> • Must provide access to the permanent pool level of the sediment forebay and wet cell and designed to support maintenance vehicles. • Max. gradient of 10%, crossfall of 2%. • Min. width of 3.0 m. • Min inside turning radius of 10.0 m. • Bollards or gates to discourage vehicular access to the maintenance road must be installed.
Flow Control Structures	<ul style="list-style-type: none"> • Must be located at any easy access point for maintenance and cleaning purposes. • Must be protected from public access. • Must blend into surrounding landscape (railings are to be avoided where possible).
Pond Draindown	<ul style="list-style-type: none"> • If possible, a gravity outlet outfitted with a valve is to be provided for the drawdown of the pond. • The valve must be directly accessible in a chamber or structure. • If a gravity outlet is not available, a perforated pipe leading to a dewatering sump is to be provided. The sump is to be located as close to the pumping outlet as possible. • A gravity outlet or dewatering sump is to be provided in the forebay for draindown into the wet cell.
Bypass Sewer	<ul style="list-style-type: none"> • To be installed between inlet and outlet. • Outfitted with a normally closed valve or gate, in an accessible location for maintenance vehicles.
Emergency Shut Off	<ul style="list-style-type: none"> • A valve is required on the extended detention outlet in order to temporarily shut off the pond outlet during emergency contaminant spill conditions.

33.2 Operations and Maintenance Manual

A SWM Facility Operations and Maintenance Manual is to be prepared for the Town by proponents of new SWM facilities. The manual is to describe how each facility operates and the short term and long term inspection and maintenance requirements of the facilities. The manual shall also include estimated yearly maintenance costs for the facilities along with supporting calculations. Any collection system SWM components, such as oil and grit separators are to be included in the manual.

A list of typical items that should be included in the manual is as follows:

- Location
- Design Drawings
- Type of SWM Facilities
- Pond Specifics
 - How does the facility work (describe methodology of typical events)

- Design Values for Facility (volumes, elevations, discharges, design event, over topping, etc.)
- Detention Time/Drain Down Time
- Reduced Scale Plan of Facility
- Inspection (what to check, frequency)
- Sediment (anticipated volume, frequency of removal, disposal, testing)
- Instructions for drawdown/dewatering (valve operation details)
- Maintenance (grass cutting, weed control, vegetation replanting, garbage removal, etc.)
- Design life and maintenance schedules.

Additional items as per the MOE's latest Stormwater Management Planning and Design Manual should also be included as deemed appropriate for the particular facility.

34.0 STORMWATER CONVEYANCE SYSTEM SIZING

34.1 General

Urban stormwater conveyance systems may include open channels and swales, storm sewers, manholes and catchbasins, foundation drainage collectors, roadways and road allowances. The design of stormwater conveyance systems shall follow "dual drainage" principles, which consist of:

- the minor drainage system which conveys runoff from the 1:5 year return period storm
- the major drainage system which conveys runoff from storms greater than the 1:5 year return period up to the 1:100 year storm.

The design of the minor drainage system shall include both the capture of and conveyance of the 1:5 year storm event. The system must provide un-surcharged conditions during the minor event. The minor system design shall include capacity for connection of foundation drains or weeping tiles and the storm sewers shall be at an appropriate depth to provide connection to foundation drains. As an alternative to connecting foundation drains or weeping tiles to the storm sewer, a Foundation Drain Collector (FDC) sewer system may be considered by the Town. The use of sump pumps is to be avoided where possible. However, they will be considered if they are the only viable option available.

A hydraulic gradeline analysis shall be completed and submitted for review. Sufficient inlet control devices at appropriate locations shall be determined by the Design Engineer to ensure un-surcharged conditions are maintained in the minor system during the 1:100 year storm event.

The design of the major system shall be such that runoff is conveyed within the boundaries of municipal road allowances, blocks or easements. A continuous overland flow route is to be identified on the Engineering Drainage Plans. See Table located in Section 34.3 for major system capacities in various road right of ways.

34.2 Minor Drainage System Design

Storm sewers should be sized to convey the peak design flow in accordance with Manning's equation, whereby the friction slope is assumed the same as the bed slope of the pipe.

$$Q = \frac{1000AR^{2/3}S^{1/2}}{n} \quad V = \frac{R^{2/3}S^{1/2}}{n}$$

Where

Q = flow (L/s)

V = velocity (m/s)

R = hydraulic radius (m)

S = slope (m/m)

A = nominal cross sectional area of the sewer (m²)

The sizing of sewers at slopes greater than the critical slope is limited by inlet capacity and not friction slope. Table 3 lists the maximum allowable flow rate for each sewer size. The table also lists the maximum pipe slopes based on a full flow velocity of 4.0 m/s. The critical slope is based upon the pipe flowing 85% full.

The values listed in Table 3 must be incorporated into storm sewer design sheets and carried through to Hydraulic Grade Line calculations.

Modified Rational Method

The Modified Rational Method is most appropriate when used to estimate peak flow rates from small urban areas. Its accuracy increases with imperviousness and decreases with the size of the drainage area. Its application should be limited to situations where the time of concentration is less than approximately 30 minutes.

Initial Time of Concentration

The initial time of concentration, to be used to determine total time of concentration, should be calculated using the following methods, subject to the runoff coefficient:

<u>Method</u>	<u>Condition</u>
Airport Method	C < 0.4
Bramsbey-Williams	C > 0.4

Airport Method:

$$T_c = \frac{(1.1 - C)L^{0.5}}{S_w^{0.33}}$$

Where

T_c = Time of Concentration (minutes)

C = runoff coefficient

L = length (m)

Sw = slope (%)

Bramsbys Williams Method:

$$T_c = \frac{0.057L}{S_w^{0.2}A^{0.1}}$$

T_c = Time of Concentration (minutes)

L = length (m)

Sw = slope (%)

A = Area (ha)

Typical initial T_c values are listed for various land uses in the following section, and should be used as the minimum value.

Runoff Coefficients

The Table below lists example Rational Method Runoff Coefficients as a function of the imperviousness of the catchment being considered. Composite runoff coefficients are to be calculated as a function of both total imperviousness and storm return period. The total imperviousness ratios listed in the table below are for example purposes only and designers should calculate actual runoff coefficients on a site-specific basis for all designs.

Typical Runoff Coefficients and Initial Times of Concentration

	Return Period	1:5	1:25	1:100	Initial T_c (Minutes)
	C_{perv}	0.20	0.30	0.40	
	C_{imp}	0.90	0.95	1.00	
	Typical				
	Impervious	Composite 'C'			
Field/Woodlot	0%	0.20	0.30	0.40	25
Parks	10%	0.27	0.37	0.46	15
Estate Res.	35%	0.45	0.53	0.61	15
Single Res.	55%	0.59	0.66	0.73	7
Semi-Det. Res.	65%	0.66	0.72	0.79	7
Townhouses	75%	0.73	0.79	0.85	7

	Return Period	1:5	1:25	1:100	Initial Tc (Minutes)
Apartments	60%	0.62	0.69	0.76	8
School	60%	0.62	0.69	0.76	8
Church	70%	0.69	0.76	0.82	8
Industrial	80%	0.76	0.82	0.88	8
Commercial	90%	0.83	0.89	0.94	7

Roughness Coefficients

Manning's formula shall be used in determining the subcritical capacity of all storm sewers and channel, as outlined above.

The value of the roughness coefficient 'n' used in the Manning's formula shall be as follows:

- All smooth walled pipes 0.013
- Concrete Box Culverts 0.015
- Corrugated Steel (culverts only) 0.024

See Section 34.3 for other Manning roughness coefficients.

Flow Velocities

- Minimum full flow velocity = 0.8 m/sec
- Maximum full flow velocity = 6.0 m/sec

Minimum Sizes

The minimum size for a storm sewer main shall be 300 mm in diameter, and as stipulated by Q Maximum in the table below.

Minimum and Maximum Grades

The minimum and maximum grades for all storm sewers shall be in accordance with the table below. The minimum grade for the first upstream leg shall not be less than 1.0%.

Allowable Storm Sewer Capacities and Gradients

Diameter (mm)	Q Maximum (m ³ /s)	Slope Minimum (%)	Slope Critical (%)	Slope Maximum (%)
300	0.12	0.34	1.34	19.00
375	0.20	0.25	1.25	14.10

Diameter (mm)	Q Maximum (m ³ /s)	Slope Minimum (%)	Slope Critical (%)	Slope Maximum (%)
450	0.32	0.20	1.17	11.10
525	0.47	0.20	1.12	9.00
600	0.66	0.20	1.07	7.50
675	0.88	0.20	1.03	6.40
750	1.1	0.20	0.99	5.60
825	1.5	0.20	0.96	4.90
900	1.8	0.20	0.93	4.40
975	2.2	0.20	0.91	3.90
1,050	2.7	0.20	0.89	3.60
1,200	3.7	0.20	0.85	3.00
1,350	5.0	0.20	0.81	2.60
1,500	6.5	0.20	0.79	2.22
1,650	8.2	0.20	0.76	1.96
1,800	10	0.20	0.74	1.74
1,950	13	0.20	0.72	1.57
2,100	15	0.20	0.70	1.42
2,250	18	0.20	0.69	1.29
2,400	21	0.20	0.67	1.19
2,700	28	0.20	0.65	1.02
3,000	37	0.20	0.62	0.88

The Town may consider flatter grades for large sewers, in special circumstances, provided a minimum velocity of 1 m/s can be attained.

34.3 Major Drainage System Design

A continuous overland flow drainage route is to be identified on the engineering drawings and grading plans. No major system overland flow during a 1:100 year storm shall use private property and must be limited to rights of ways and public property. Any inlet grating associated with the major drainage system is to include a 50% blockage factor in its design.

Any 1:100 year storm sewer capture situations are to be avoided where possible. In cases where no other options are available, redundancy in the system must be provided such that a localized spill point is provided before flooding of private properties occurs. If a spill point does not exist, additional high capacity inlets are required to provide redundancy.

Roadway Major System

Generally, road right-of-ways vary in width from 18.0 metres to 26.0 metres and have a gradient in the supercritical range of 0.5% to 6%. The flow carrying capacity is predominately influenced by the boulevard cross-slopes, whereby steeper boulevards provide for deeper flow. Designers should set the boulevard slopes accounting for the need to convey overland flow, but must have regard for other constraints which affect boulevard cross slopes (i.e. maximum permissible driveway grades). Boulevard slopes of 2% are to be used unless a steeper slope is required for overland flow conveyance.

The following graph provides the right-of-way flow carrying capacity for various pavement/ROW widths, in m³/s:

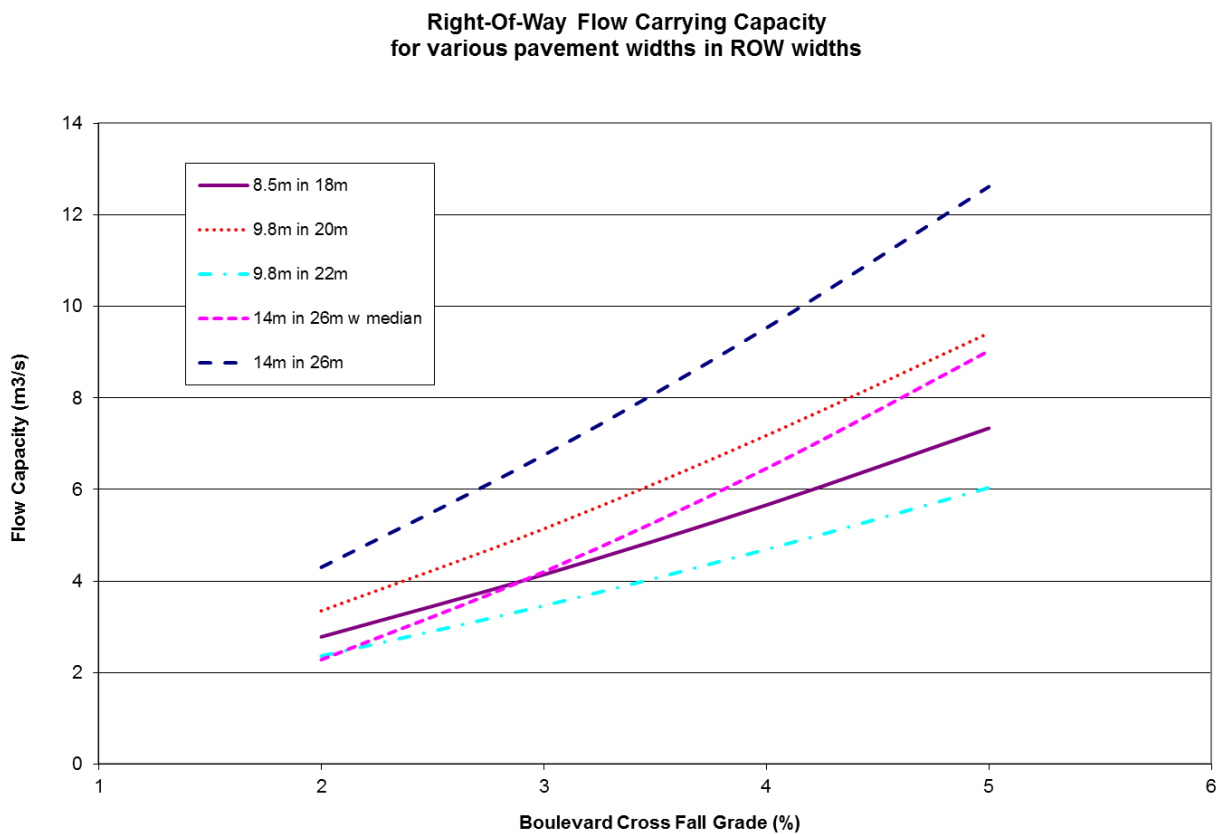

Walkways are hydraulically similar to roadways, but rely more on curb height instead of boulevard slope. Where required, curb heights for walkways can be installed between 0.15 metres and 0.30 metres. Minimum and Maximum longitudinal walkway gradients are 0.5% to 6%.

Swales and Open Channels

Swales and open channels can play an important role in both the major overland flow systems and the minor systems. They are to be designed to be aesthetically pleasing,

safe, resistant to erosion and easy to maintain. Design velocities are to be calculated using Manning's equation and need to consider critical depth.

The following table provides acceptable values for Manning's "n":

Grass Channel (>0.5 m deep)	0.025
Grass Swale (<0.5 m deep)	0.030
Rip-Rap Channel (>1 m deep)	0.035
Rip-Rap Channel (<1 m deep)	0.040

Generally, grassed surfaces are adequate for velocities up to 1.0 m/s to 1.5 m/s and more robust erosion protection is required for velocities beyond this range.

Fences, garden sheds and other flow impediments significantly reduce the flow carrying capacity of swales on private property. Overland flow from public property onto swales on private property is not permitted. Overland flow must be limited to road right-of-ways, walkways and easements, free of fences and other impediments to flow.

34.4 Foundation Drain Collector Systems

In areas where it cannot be demonstrated that the hydraulic gradeline for the 1:100 year storm will be at least 0.5 metres below the finished basement floor elevations of the dwellings, a separate dedicated foundation drain collector sewer (FDC) will be constructed to carry flows from the weeping tile collector systems. The FDC will have a protected free outlet above the higher of the Regional storm water elevation or the 1:100 year storm HGL. No other sources of flow are allowed.

35.0 STORMWATER CONVEYANCE SYSTEM DESIGN

35.1 Pipe Cover

Typically a minimum cover of 2.7 metres (from future road grade) is required to the top outside edge of the pipe barrel for the storm sewer. However, where specifically approved by the Town, minimum frost cover of 1.4 metres may be provided on storm sewers where servicing limitations exist, or where FDCs are used.

The maximum depth of sewers with direct lateral connections shall be 8.0 m (measured from finished centerline of road elevation to invert of sewer). In cases where deeper sewers are required these shall be considered trunk sewers and no direct lateral connections will be permitted. Separate local sewers constructed above the trunk sewers will be required for connection of laterals. Manholes are to be common wherever possible with drop structures.

35.2 Location

All storm sewers shall be located as shown on the Standard Road Cross-Section. The standard location shall generally be 1.5 m offset from the centerline of the road allowance.

All storm sewers are to have a minimum horizontal separation of 2.5 m and a vertical clearance of 0.5 m from watermains in accordance with MOE regulations.

35.3 Termination Points

All sewers shall be terminated at the subdivision limits when external drainage areas are considered in the design with suitable provision in the design of the terminal manholes to allow for the future extension of the sewer.

35.4 Sewer Alignment

All storm sewers shall be laid in a straight line between manholes unless radial pipe has been designed as outlined in Section 36.9.

35.5 Pipe Crossings

A minimum clearance of 75 mm shall be provided between the outside of the pipe barrel at the point of crossing for storm and sanitary sewers. A minimum clearance of 0.5 m shall be provided for all sewer and watermain crossings.

In the event the minimum clearances cannot be obtained, the designs must adhere to MOE policies. In addition the pipes shall be concrete encased to ensure that the pipes are properly bedded.

35.6 Changes in Pipe Size

No decrease of pipe size from a larger upstream pipe to a smaller downstream size will be allowed due to the increase in grade.

35.7 Pipe Bedding and Backfill

The class of pipe and the type of bedding shall be selected to suit loading and proposed construction conditions. Details and types of bedding and backfill are illustrated in OPSD 802.010 and 802.030. The width of the trench at the top of the pipe must be carefully controlled to ensure that the maximum trench width is not exceeded unless a higher class of bedding or higher pipe strength pipe is used. The recommendations of a Geotechnical Engineer will be required in determining strength of pipe required and construction methods to be used.

36.0 MANHOLES

36.1 Location

Manholes shall be constructed at the following locations:

- at changes in pipe size
- at pipe junctions
- at changes in pipe slope

- at changes in pipe alignment
- at changes of pipe material (example: PVC to concrete)
- at intermediate intervals as per Section 36.2.

The outside wall of any manhole structure located within the roadway shall not be located closer than 1.5 m to a curb. The manholes shall be oriented in such a way that the access cover is offset towards the centerline of the road.

36.2 Maximum Spacing of Manholes

Pipe Size	Maximum Spacing
300 mm to 750 mm	100 m
825 mm to 1200 mm	120 m
1350 mm to 1800 mm	150 m
over 1800 mm	210 m

36.3 Manhole Types

Manholes shall be constructed of pre-cast concrete. The standard manhole details as shown on the OPS Drawings shall be used for manholes. In cases where the standard drawings are not applicable, the manholes shall be individually designed and detailed.

A reference shall be made on all Profile Drawings to the OPSD type and size of all storm manholes.

Precast manholes shall conform to ASTM Specification C478 latest revision.

36.4 Manhole Frame and Covers

Manhole covers shall be the “open” type per OPSD 401.010.

All manholes located within the travelled portion of the roadway shall have the rim elevation initially set flush with the base course asphalt. A maximum of 300 mm height of modular rings shall be permitted on all manholes in new subdivisions.

Prior to the placement of the final course asphalt, the manhole frame shall be adjusted to suit the final surface asphalt elevation.

36.5 Manhole Design

- All manhole chamber openings shall be located on the side of the manhole parallel to the flow for straight run manholes, or on the upstream side of the manhole at all junctions.
- The manhole shall be centered on the sewer main.
- All manholes shall be benched throughout to the crown of all pipes on a vertical projection from the spring line as detailed in the OPS Drawings.

- d) Safety gratings shall be required in manholes in accordance with OPS Specifications. Where practical, safety gratings shall be located 0.5 m below the drop structure inlet pipe.
- e) Galvanized steel safety chains and fittings are to be provided on the downstream side of a manhole where the outlet pipe is 1200 mm diameter or greater. The chains shall be attached to the face of the manhole at the 10 o'clock and 2 o'clock positions on either side of the outlet pipe.

36.6 Drop Structures

Drop structures shall be used when invert levels of inlet and outlet sewers differ by 0.9 m or more. The size of the drop pipe shall be one size smaller than the storm sewer diameter and shall have a maximum size not exceeding 300 mm in diameter. Wherever feasible, sewer systems should be designed to avoid the use of drop structures. Internal drop structures are not permitted. Precast drop structures are permitted. All drop structures shall be constructed in accordance with OPSD 1003.020.

36.7 Head Losses through Manholes

The maximum change in the direction of flow in any sewer manhole shall be no more than 90 degrees. Sewers up to 600 mm in diameter may be turned a maximum of 90 degrees. Sewers greater than 600 mm in diameter may be turned a maximum of 45 degrees. In extreme cases, deviations from the above guidelines may be permitted by the Town provided acceptable supporting hydraulic calculations are provided.

Suitable drops shall be provided across all manholes to compensate for the loss of energy due to the change in flow velocity and for the difference in the depth of flow in the sewers. Hydraulic calculations are required where the change in velocity through a manhole is 0.6 m/s or greater.

The minimum drops across manholes shall be as follows:

Change of Direction	Minimum Drop
Straight Run	0.030 m
1 to 45 degrees	0.050 m
46 to 90 degrees	0.100 m

36.8 Prefabricated Wyes

The use of prefabricated Wyes is recommended for junctions in storm sewers under the following conditions:

- Main pipe must be 900 mm in diameter or larger. (If less than 900 mm in diameter a manhole is required for the junction.)

Diameter of Branch Pipe	Maximum Distance from Point of Junction to 1 st M/H Upstream on Branch Pipe
Less than 750 mm dia.	15 m
750 mm to 1350 mm dia.	120 m
Larger than 1350 mm dia.	180 m

36.9 Radius Pipe

- No radial pipe will be allowed for pipe having a diameter of less than 675 mm. For pipes 675 mm and larger radial pipe will be considered by the Town based on the specific application being proposed.
- No wedge pipe will be permitted in any case.

37.0 CATCHBASINS

37.1 Location and Spacing

- The maximum allowable drainage path to a catchbasin is as follows:

Pavement Width (Metre)	Maximum Spacing (Metre)
8.5 m	90 m
9.8 m	80 m
14.0 m	65 m

- The minimum catchbasin density which must be provided is to be 6 catchbasins per impervious hectare of area.
- A double catchbasin is required where drainage is received from more than one direction, as at a low point, unless overland relief is provided no more than 0.05 m above the catchbasin frame.
- All catchbasins at street intersections shall be located on the tangent section of the curb at a minimum of 0.6 m distant from the beginning or the end of the radial portion of the curb.
- Catchbasins shall not be located in driveway curb depressions.
- Leads for catchbasins located close to manholes should be connected directly to the manholes.
- Catchbasin leads shall be 250 mm diameter for single catchbasins and 300 mm diameter for double catchbasins.
- All catchbasin leads shall be connected to storm sewers with prefabricated tees as per OPSD standards.
- All catchbasin lead connections to manholes shall be done with prefabricated PVC manhole adapters.

- Catchbasin leads shall have a minimum grade of 1%.
- Catchbasin inlet control devices are to be PVC with “diamond” orifices and bolted to the catchbasin side.

37.2 Catchbasin Capture

- Calculations to estimate the catchbasin capture to the sewer system are to consider the type of grate, whether the catchbasin is in a “sag”, the catchbasin lead diameter and any inlet control device.
- Double catchbasins are required at all sags, unless there is a nearby point of relief, no greater than 0.05 m higher than the grate. Capture rates are to consider the depth of flow over the grate based on the depth of flow over the downstream point of relief.

37.3 Catchbasin Types

- Catchbasins must be of the precast type as shown on the OPS Drawing 705.010 or 705.020.
- All rear lot catchbasins are to be sumpless.
- Special catchbasins and inlet structures shall be fully designed and detailed by the Consulting Engineer.

37.4 Catchbasin Connections

Type	Minimum Size of Connection	Minimum Grade of Connection
Single Catchbasin	250 mm	1%
Double Catchbasin	300 mm	1%
Rear Lot Catchbasin	* 250 mm	1%

* All rear lot catchbasin leads shall be encased in concrete from the catchbasin to the street line as outlined in Section 23.5 and Section 54.3.

37.5 Catchbasin Frame and Covers

- All catchbasin frame and covers located in roadways shall be “bike proof”.
- Rear lot catchbasin frame and covers shall be as per the Standard Drawing included in the Appendix.
- The use of rivetted bar grates in roadways will only be considered in special circumstances at the discretion of the Town. These must be bicycle safe and able to withstand traffic loads.

38.0 STORM SERVICE CONNECTIONS

38.1 General

Storm service connections are to be provided to all lots for the purpose of connecting foundation drain collectors. All storm sewer connections for single, semi-detached and Townhouse lots shall be made with single service pipes and shall conform to Ontario Provincial Specifications. All connections are to have a PVC test fitting installed at the property line. The sewer connection shall extend 1.5 m inside of the property line and terminate with a plug. The pipe is to be white in colour and marked with a 50 mm x 100 mm x 2.4 m stake painted white.

The use of sump pumps is discouraged, but will be considered by the Town if they are deemed to be the only viable option available. (Roof leaders shall be directed overland.) The storm sewer system shall be designed such that the 1:100 year storm does not surcharge the sewers or create backwater effects that could surcharge the weeper tiles within 0.5 m of the finished basement level.

38.2 Location

The proposed location of the storm sewer service shall be shown on the Plan and Profile Drawings and Composite Utility Plans. The location shall be as per the Standard Drawing included in the Appendix.

38.3 Size

Service connections for single family and semi-detached (or linked) units shall be 125 mm in diameter. Service connections for multiple family blocks, commercial, institutional and industrial areas shall be sized according to the intended use.

38.4 Connection to Main

The connection to the main sewer shall be made with an approved manufactured tee. Approved saddles shall be used for connecting to existing sewer mains.

Connection to manholes will be allowed only if the invert is connected no higher than the obvert of the outlet pipe in the manhole and properly benched.

No service connection of a size greater than half the diameter of the main shall be cut into the main sewer. A manhole shall be installed on the main sewer at the intersection of a service connection which has a size greater than half the diameter of the main sewer except as provided below.

A 150 mm service connection will be permitted to connect to a 250 mm main sewer provided an approved manufactured tee is installed and provided the invert of the service connection is above the spring-line of the main sewer.

38.5 Depth

The depth of the service connections for single family units, semi-detached units and Townhouses at the property line measured from the finished centre line road elevation shall be:

- Minimum – 2.50 m
- Maximum – 3.00 m (unless proposed house types require deeper service depths).

Risers shall be used when the obvert depth of the sewer main exceeds 4.50 m. The riser section shall be brought to a depth of within 3.0 m.

38.6 Connection to Multiple Family and Other Blocks

An inspection manhole shall be required on the private property (1.5 m from property line to centre of the frame and cover) on all connections to multiple family and other blocks.

38.7 Connection to Commercial/Industrial Institutional Blocks

An inspection manhole shall be required on private property located 1.50 m from the property line to the centre of the frame and cover.

39.0 INLETS, OUTFALLS AND SPECIAL STRUCTURES

Inlet and outfall structures, including headwalls shall be designed and detailed by a Structural Engineer.

Grates will be provided on all inlet and outlet structures and shall be designed and detailed when standard drawings are not appropriate. All metal parts shall be galvanized to adequately protect against rusting.

39.1 Inlets

Inlet structures must be fully designed and detailed on the engineering drawings. Inlet grates shall generally consist of galvanized inclined parallel bars or rods set in a parabolic shape as determined with input from the Town.

Precaution must be taken in the design of grating for structures to minimize the risk of entanglement or entrapment of a person.

Gabions, rip rap or concrete shall be provided at all inlets to protect against erosion and to channel flow to the inlet structure.

39.2 Outlets

The OPSD 804.030 standard headwall shall be used for all storm sewers less than 900 mm in diameter. For sewers 900 mm in diameter and larger the headwall shall be in accordance with OPSD 804.040 or individually designed. All headwalls shall be equipped with a grating over the outlet as per OPSD 804.050.

Gabions, rip rap, concrete or other erosion protection shall be provided at all outlets to prevent erosion of the watercourse and the area adjacent to the headwall.

39.3 Safety Railings

Safety railings shall be provided along the top of all headwalls 0.6 m in height or greater. Railings may also be required along shorter headwalls where a risk to pedestrian safety has been identified. The site specific conditions must be reviewed in determining the requirement for safety railings and must have due regard to public health and safety.

40.0 PIPE MATERIALS

A list of acceptable pipe materials is included in the Appendix.

41.0 SUBMISSION REQUIREMENTS FOR SWM DESIGN REPORTS

The following is a list of documentation which should be included within SWM design reports submitted to the Town for review. These reports are submitted to support the final design of quality and/or quantity control facilities. These reports shall clearly identify how applicable recommendations from Master Servicing, Functional Servicing, Geotechnical, Environmental or Hydrogeological Reports have been incorporated into the final design of the facility.

- a) Site Location Plan.
- b) Existing and proposed catchment area plan which delineates internal/external drainage areas and labels areas and catchment reference numbers.
- c) Engineering plans for stormwater facilities which should identify the following:
 - permanent, extended detention, highest water levels on plan view and include all ponding levels for various return periods in tabular form,
 - section/details of major overland flow routes,
 - section/details of maintenance access roads,
 - section/details of erosion protection at inlet/outlet structure and on spillways,
 - fencing limits,
 - location of facility signage,
 - borehole location and existing groundwater elevation,

- existing and proposed grading elevations and transition slopes,
 - sediment forebay details including lining and separation berm,
 - details of sediment drying area and/or by-pass pipe for cleaning purposes,
 - section/details of inlet/outlet structures.
- d) Landscaping/restoration plans and details.
- e) Erosion and sediment control plans and details.
- f) Excerpts from Master and Functional Studies which outline requirements for quantity/quality control and any facility design requirements.
- g) Identify any deviations from the Town Design Criteria including an explanation based on site specific conditions.
- h) Pre and post development hydrologic modeling schematic to illustrate all components of each model.
- i) Table summarizing pre and post development catchment parameters (i.e. catchment number, area, percent impervious, CN value, etc.).
- j) Table summarizing stage, storage and discharge characteristics of the facility.
- k) Table summarizing pre and post development peak flows and storage volumes based on output from hydrologic modeling or comparison to volumes and target peak flows identified in Master and Functional Servicing Studies.
- l) Table to summarize and compare required permanent pool and extended detention storage requirements to volumes provided in the facility.
- m) Table to compare calculated 1:100 year hydraulic grade line elevations within storm sewer system to estimated underside of basement floor slab elevations.
- n) Sample or supporting calculations for the following:
- extended detention drain downtime (hours),
 - major system overland flow and velocity to confirm conveyance within R.O.W. and/or defined flow routes,
 - erosion control sizing and flow velocity at inlet/outlet structures and spillways,
 - sediment forebay length and width in conformance with MOE manual,
 - major system inlet grating sizing (assuming 50% blockage).
- o) Hard and digital copies of input/output files from hydrologic modeling (digital files may be provided on CD or via e-mail).
- p) Identify erosion and sediment control methods to be implemented before, during, and after municipal servicing construction up to the end of servicing maintenance period, including schedule for implementation/decommissioning and maintenance requirements.

- q) Any HGL above the storm sewer obverts is to be shown on the sewer profile drawings.



Town of
East Gwillimbury

SECTION H

WATERMAINS AND APPURTENANCES

Town of East Gwillimbury
Engineering Standards and Design Criteria

September 2012

SECTION H – WATERMAINS AND APPURTENANCES

42.0 HYDRAULIC DESIGN

42.1 General

All watermains shall be sized to meet the greater of the maximum day plus fire flow or the maximum hour demand. Watermains in subdivisions shall have a minimum of two (2) connections to the existing water network. The Town will require a computer analysis for all or any phased portion of the proposed watermain systems. Boundary conditions for modeling purposes shall be obtained by carrying out on-site hydrant flow tests in consultation with the Town. All data shall be provided to the Town.

42.2 Fire Flow

In general, the minimum fire flow requirement for particular land uses in the municipality shall be:

- Residential 4,800 L/min
- Employment 12,000 L/min

The Town may at its discretion require calculations to be provided as outlined in “Water Supply for Fire Protection - A Guide to Recommended Practice” prepared by the Fire Underwriters Survey of the Insurance Bureau of Canada, or, per AWWA Manual M31 - Distribution System Requirements for Fire Protection.

42.3 System Pressures

The maximum sustained operating pressure shall not exceed 700 kPa (100 psi). If pressure in a localized area is above this level, a pressure reducing valve shall be installed on each service downstream of the water meter within that area.

Under normal conditions of maximum hour demand, the pressure shall not drop below 275 kPa (40 psi) at any point in the water system.

Under conditions of simultaneous maximum day and fire flow demands, the pressure shall not drop below 140 kPa (20 psi) at any point in the water system.

42.4 Flow Design

The Hazen-Williams Formula in accordance with the current Ministry of the Environment design criteria shall be used for the design of water distribution systems.

The Hazen-Williams equation is as follows:

$$H_L = \frac{C_f L Q^{1.852}}{C^{1.852} D^{4.87}}$$

Where,

H_L = headloss due to friction (m or ft)

C_f = unit conversion factor (4.73 for Imperial, 10.7 for Metric)

L = watermain length (m or ft)

D = diameter (m or ft)

Q = watermain flow (m³/s or cfs)

C = Hazen-Williams Factor

$C = 100$ for 150 mm watermain and smaller

$C = 110$ for 200 mm and 250 mm watermain

$C = 120$ for 300 mm watermain and bigger

42.5 Domestic Demand

Domestic water demand shall be calculated on the basis of an average day consumption rate of 350 Litres/capita/day, or as directed by the Town.

Maximum Day and Peak Hour factors shall be 2.0 and 2.75 respectively, or as recommended by the Ministry of the Environment.

The following densities should be used for determining expected populations in residential developments:

Single Detached Dwellings	=	3.36 ppu
Semi-Detached Dwellings	=	3.36 ppu
Townhouses	=	2.78 ppu
Apartments	=	1.76 ppu

42.6 Industrial, Commercial and Institutional (ICI) Water Demands

The follows rates average day demands shall be used for ICI uses:

Industrial	=	35,000 L/ha/d
Commercial	=	28,000 L/ha/d
Institutional	=	18,000 L/ha/d

42.7 Locations

Watermains shall be located in boulevards as shown on the Town of East Gwillimbury Standard Roadway Cross-Sections.

42.8 Depth of Cover

The minimum depth of cover shall be 1.7 metres measured from top of pipe to centerline road grade.

42.9 Horizontal Separation between Sewers and Watermains

Watermains shall be designed to have a minimum clear distance of 2.50 metres from any sewer or manhole.

42.10 Watermain Crossing Sewers and Other Utilities

Watermains shall normally cross above sewers with sufficient vertical separation to allow for proper bedding of the watermain (minimum 0.3 metres).

When it is not possible for a watermain to pass over a sewer, the watermain passing under the sewer shall have a vertical separation of 0.50 metres below the sewer and the top of the watermain. The sewer must be adequately supported to prevent settling and displacement of the joints.

Watermains crossing over or under other utilities must be designed with a vertical separation of 150 mm between the outside edges of the watermain and the utility.

42.11 Dead-Ends

Watermain distribution system shall be designed in grid patterns and looped to avoid dead-end sections. Dead-end watermains are to be avoided.

In extreme situations, as determined by the Town, where it is determined that dead-end watermains are unavoidable automatic flushing units shall be installed at the end of the watermain. The automatic flushing units shall be as per the Standard Drawing included in the Appendix to this document. Water service connections shall be grouped at the end of the dead-end watermain as much as possible or a 50 mm loop shall be constructed to provide adequate circulation. Calculations shall be provided to demonstrate that there is adequate water usage during low flow periods to maintain adequate chlorine residual levels at all times within the watermain.

Temporary dead-ends on watermains that are to be extended in the future shall be equipped with a 50 mm blow-off at the end of the watermain per OPSD 1104.030.

42.12 Location Identification

A tracer wire shall be provided along the top of all watermains to permit field tracing of the watermain. The wire is to be secured to the top of the watermain at every fitting and valve and at intervals not to exceed 3.0 metres. All tracing wires shall be 12 gauge, stranded copper wire complete with outer plastic coating.

Tracer wire shall be connected to valves in chambers and the tracer wire is to be carefully extended along the bottom of the chamber, up the backside of the steps along the chamber wall and securely fastened to the top rung with fiberglass tape.

Tracer wire is to be continuous with no joints. Where joints are needed (between rolls) they are to be soldered together plus wrapped in dielectric tape over wrapped with vinyl tape.

Confirmation of the continuity of the tracer wire installation is to be provided in writing by the Owner's Consulting Engineer as part of the commissioning of the watermain system.

42.13 Joint Restraint

Mechanical joint restraints are to be installed on bell and spigot joints for all watermains constructed in fill material and at all tees, horizontal bends, vertical bends, hydrants, end of mains and valves. The use of concrete thrust blocks is generally discouraged and they will only be permitted where deemed absolutely necessary by the Town. All mechanical restraint systems shall be installed with cathodic protection as outlined in Section 48.0.

43.0 VALVE REQUIREMENTS

Number, Location and Spacing

Two valves are required on tee intersections and three valves are required on cross intersections with the valves being placed at a point where the street line projected, intersects the watermain. All valves are to be located in chambers. The valve chambers are to be located in the boulevards and out of the pavement areas. Under no circumstances will valve chambers be permitted in driveways. In addition chamber lids are not to be installed in sidewalks.

Valve spacing along a watermain shall not exceed 300 m, or for every 40 lots, whichever is less.

The Town may, at their discretion, require additional valves to be installed beyond the requirements noted above to ensure adequate isolation during construction, to allow for future development connections or to provide adequate isolation of watermains.

Size

In all cases, the size of the line valves shall be the same size as the watermain diameter.

Valve Chambers

All valves shall be located in chambers and shall be resilient wedge gate valves as approved by the Town. Valves shall have a non-rising stem and a 50 mm square

operating nut, opening counter-clockwise. The valves shall have mechanical joint fittings.

The cover and plug shall be aligned over top of the valve operating nut. Where the valve and cover are offset (under extenuating circumstances only), the chamber is to be cored with a valve box for operation.

Any valves deeper than 2.4 m require the operating nut to have a valve stem extension.

All chambers are to have the tracer wire extend from the valve along the bottom of the chamber up the backside of the steps along the chamber wall and securely fastened to the top rung with fiberglass tape.

Wherever possible, valve chambers shall be provided with a storm drain connection to the storm sewer. The diameter of the drain pipe shall be 150 mm. Where it is not possible to provide a direct connection to the storm sewer 300 mm X 300 mm X 300 mm sumps shall be provided in the base of the chamber located directly below the chamber access hole.

43.1 Special Valves

Drain valves and air release valves may be required based on specific site conditions. These requirements will be determined during the design review process.

44.0 FIRE HYDRANT REQUIREMENTS

44.1 Spacing

Fire hydrants shall be provided at 120 m maximum spacing in residential areas and 90 m maximum spacing in industrial/commercial areas. For residential areas hydrant shall be spaced such that all lot areas are within a 75 m radius from a hydrant.

Whenever possible hydrants should be located at high points in the watermain to minimize the requirement for air release valves.

44.2 Type

All fire hydrants shall be Canada Valve **only** and are to be equipped with one (1) 100 mm pumper port with manufacturer's "Stortz" fitting facing the street. The side ports shall be 65 mm diameter. Hydrants are to be supplied with a hose nozzle cap chain and S-hook and are to be painted chrome yellow. Hydrant port caps are to be painted green.

All hydrants shall be installed in accordance with OPSD 1105.010, have open drainage holes and be installed with mechanically restrained joints (without thrust blocks). The hydrant base is to be installed in open-graded granular material enclosed with a geotextile fabric to ensure free draining of the boot. In areas of known high water, the

hydrant drain holes shall be plugged and the Town shall be advised. This is to be reflected on the Record Drawings.

The hydrant is to be set at such a height that the distance from the finished ground around the hydrant to the bottom of the flange is between 50 mm and 150 mm.

All hydrants shall be fitted with anti-tampering devices of a type required by the Town.

44.3 Branch Valves and Boxes

All hydrants shall be controlled by a 150 mm diameter branch valve attached to the supply main with an anchor tee. Where this would place the secondary valve in the road, the valve is to be placed in the boulevard and have restraining rods back to the tee on the main.

44.4 Location of Hydrants

Hydrants shall be located on the projection of a lot line and offset from the street line in accordance with the standard cross-section.

Hydrants shall be 1.20 m minimum distance from the edge of any driveway or house service location. Other aboveground utilities such as light standards, transformers or street signs shall not be located any closer than 3.0 m to a hydrant.

44.5 Hydrant Flow Testing

The Developer's Consulting Engineer shall carry out a flow test in accordance with the Ontario Fire Code. Following the flow test the Developer's Consulting Engineer is to provide a written report to confirm that the minimum flows and residual pressures will be met when the subdivision is fully developed.

45.0 SERVICE CONNECTIONS

45.1 General

A single water line shall be installed to service each residential property. Services for other uses are to be adequately sized and identified on the engineering drawings. Services shall be installed according to OPSD 1104.010 and 1104.020.

45.2 Material

All domestic water service connections shall be constructed of Type 'K' Copper meeting the requirements of CSA 137.1. No joints or fittings will be permitted on the copper service.

45.3 Minimum Size

Single water lines serving only one residence shall be a minimum of 19 mm (3/4") in diameter.

45.4 Location

Single services shall be provided for all single and semi-detached lots and on- street townhouse units. The location shall be shown on all Plan and Profile Drawings and the Composite Utility Plans.

The minimum cover over water services shall be 1.6 m.

A minimum clearance of 1.0 m shall be provided from all water services to any storm sewer or catchbasin. If this is not achievable the water service shall be insulated.

45.5 Markers

All connections shall be marked with 50 mm X 100 mm X 2.4 m stakes painted blue.

45.6 Connections to Supply Main

The maximum size of connection that can be tapped into a 150 mm diameter watermain is 50 mm in diameter. A stainless steel saddle shall be used in all cases.

Water service connections larger than 50 mm in diameter shall be made by installing a tee on the supply main.

45.7 Curb Stops

The curb stop on all water service connections 50 mm in diameter and less shall be located at the street limit and a minimum distance of 0.3 m away from the outer edge of the driveway where possible. Frost collars shall be installed for any curb stops constructed in driveways. Curb stops are to be brass (lead free) ball valves.

46.0 COMMERCIAL AND INDUSTRIAL CONNECTION

All commercial and industrial connections shall branch into separate domestic and fire lines in a valve chamber located in the boulevard. Each line shall have individual shutoff valves. Refer to Standard Drawing included in the Appendix.

47.0 CONNECTION TO PARK BLOCKS

All park blocks are to be serviced with a minimum 50 mm diameter water connection.

48.0 CORROSION PROTECTION

For any installation of water pipe systems, an investigation of the soil conditions shall be undertaken to determine the corrosivity of the native soils and to provide recommendations with regard to corrosion protection.

As a minimum all mechanical connections are to be protected against corrosion through the use of corrosion protection duration nuts. Corrosion protection duration nuts are to

be used on 50% of all T-bolts per connection and are to be used in addition to standard fastening nuts, ***not*** in place of standard nuts.

49.0 MATERIALS

A list of acceptable materials is included in the Appendix to this document.

50.0 WATER SAMPLE STATIONS

Water quality sampling stations shall be shown on the drawings and installed in locations as required by the Town.



Town of
East Gwillimbury

SECTION I

UTILITIES
&
STREETLIGHTING

Town of East Gwillimbury
Engineering Standards and Design Criteria

September 2012

SECTION I – UTILITIES & STREET LIGHTING

51.0 GENERAL

The Town of East Gwillimbury requires that the use of aboveground utility furniture be minimized in all new developments. Accordingly common “utility poles” are required in all subdivisions.

51.1 Standard Requirements

All primary hydro, telephone, gas and cable T.V. lines shall be placed underground in locations as shown on the typical road sections listed in the Standard Drawings. Design of these utilities shall conform to the regulations of the respective authority.

52.0 COMPOSITE UTILITY DRAWINGS

All utilities are to be shown on the Composite Utility Plan and to be submitted for the review and approval of the Town. This drawing shall be prepared at a scale of 1:500, unless otherwise approved and show locations of all municipal services including sewers, watermains, laterals, manholes, catchbasins, sidewalks and driveways in addition to utilities including street lighting poles, all above and underground services and Canada Post mailbox locations. It is the Consulting Engineer’s responsibility to ensure there are no conflicts resulting from the design of the various utilities and the municipal roads and services.

All details of any entranceway features and structures within the proposed right-of-way are to be indicated on the Composite Utility Drawing, as circulated to the various utilities. The drawings shall also indicate the presence of any pumping stations or other such facilities that may necessitate particular service requirements.

- a) The Composite Utility Plan is to be approved by all individual utility agencies identified on the drawing and Canada Post, prior to final acceptance by the Town. Any revisions to the approved Composite Utility Plans will require approval of each agency. This shall be done by noting the revision in the title block of the drawing and having the title block of the drawing initialed by a representative of each agency.
- b) Community mailboxes shall be placed in locations approved by the Town and Canada Post. Community mailboxes shall have direct sidewalk access wherever practical. Prior approval from the Town will be required for any mailboxes proposed without a direct sidewalk connection.
- c) The Composite Utility Plan is to show municipal addresses as soon as these are available, as well as lot numbers.
- d) 1.5 metre separation is to be maintained between edge of driveway and all street furniture unless otherwise approved by Town.
- e) All gas services to be installed at the opposite side of the lot from Hydro Service.

- f) Underground hydro shall clear manholes and catchbasins by minimum of 1.0 metre; otherwise, concrete encasement is required.
- g) All hydro cables to be concrete capped over split duct at watermain and hydrant connection crossings.
- h) Gas mains shall clear underground structures by 300 mm minimum.
- i) Underground hydro to have 1.0 metre horizontal clearance at hydrant locations. A reduction to 0.8 metre will be permitted for 18.0 metre wide road allowances.
- j) The offices of Bell, Hydro, Gas, Cable T.V. and the Town's Operations Department must be contacted for precise locates before any digging can commence in the boulevard areas.
- k) The typical cross-section shall be shown or referenced on the Utility Drawing.
- l) A maximum of two (2) items of street furniture will be permitted on any lot.
- m) For utility clearances, refer to Table I-1. Table I-1 and the notes below are to be included on the Composite Utility Drawings.

The following represents the minimum clear separation distance for public utilities:

Table I-1: Public Utility Clearance Requirements

Condition/Utility		Gas Line	Hydro	Bell, Cable T.V.	Water/Sewer Lines
1	Minimum Vertical Distance	0.3 m	0.3 m	0.3 m	1.2 m
2	Minimum Horizontal Distance	0.9 m	0.9 m	0.3 m	1.2 m
3	Minimum Distance Below Ditch Inverts	0.6 m	0.9 m	0.3 m	1.7 m
4	Minimum Distance from Structure/Chambers	0.3 m	0.3 m	0.3 m	0.6 m
5	Minimum Distance from Hydrants	0.3 m	1.0 m	0.3 m	0.6 m

In addition, the policies for Special Protection are as follows:

Hydro Lines

- over 15 kv, install in ducts (concrete encased if under ditch)
- under 15 kv, usually direct burial except ducted under roads and concrete encased duct under ditches
- duct preferred on private property
- for all voltages, install in concrete encased duct around underground structures.

Bell and Cable T.V.

- usually direct burial but may use concrete encased duct for three or more cables.

53.0 STREET LIGHTING DESIGN

The street lighting system shall be designed by a qualified Consulting Engineer in accordance with the Illumination Engineering Society of North America (IESNA) latest edition recommendations. All street lighting systems for roadways shall meet the requirements of the Town and Hydro One.

53.1 Street Light Poles and Fixtures

A Standard Drawing is included in the Appendix to this document which identifies typical pole and fixture information.

53.2 Street Light Pole Spacing

Street light poles shall be spaced no less than 33 metres apart measured along the centerline of road.

53.3 Shop Drawing Review

The Developer's Consulting Engineer shall be responsible for the review/approval of any required shop drawings submitted by the Contractor/supplier for verification or compliance to the lighting design and Town specifications.

53.4 Energization of Street Lighting System

The Developer's Consulting Engineer or Contractor shall make all necessary arrangements with Hydro One for the connection of the lighting system.

53.5 Alternate Street Lighting Designs

It is the Town's expectation that the above noted street lighting standards will be applied to all residential subdivisions. In cases where the proponent would like the Town to consider street lighting designs which deviate from the above noted Standards, the proponent must provide the Town with justification to support the requested deviation. If the Town is agreeable to considering an alternate design, the design must conform to the specifications noted below.

Roadway lighting shall be designed using the values found in the IESNA Reference Guide Figure 22-8 and abbreviated in the following table:

Road Classification (IESNA R2 & R3)	Luminance Values		
	Average Maintained Illuminance Values (Lux/Footcandles)	Illuminance Uniformity Ratio (Average to Minimum)	Uniformity (Maximum to Minimum)
Local Residential	4.0/0.37	6 to 1	10 to 1
Collector Residential	6.0/0.56	4 to 1	8 to 1

A photometric layout will be required and must include the following information:

1. Lighting levels extending past the property line to the nearest building (light trespass on adjacent residential properties is to be kept to a minimum utilizing full cut-off flat lens luminaires and house-side shields if required).
2. Specification sheets on luminaires to be installed.
3. Average Maintained, Average to Minimum, and Maximum to Minimum calculations taken between at least four (4) lighting poles on the roadway portion of the photometric calculations are to be provided. Photometric layout LLF (Light Loss Factor) used when calculating lighting levels is to be indicated.



Town of
East Gwillimbury

SECTION J

EASEMENT REQUIREMENTS

Town of East Gwillimbury
Engineering Standards and Design Criteria

September 2012

SECTION J – EASEMENT REQUIREMENTS

54.0 GENERAL

Where underground services or utilities are placed outside road allowances or blocks of land under the ownership of the Town, permanent easements are required.

With the exception of easements required for rear lot catchbasin leads, any easements proposed for utilities, storm sewers, sanitary sewers and watermains shall be reviewed with the Town prior to the first submission.

54.1 Rear Yard Catchbasin Leads

Easements will be required for all rear lot catchbasin leads. All catchbasin leads shall be constructed 0.6 metres offset from the lot property line and located on one lot. The lead shall be 250 mm minimum in diameter and concrete encased from the rear lot catchbasin to the street line. Rear lot catchbasin leads shall connect to storm sewer manholes wherever possible.

Easement widths shall be a minimum of 3.0 metres wide for leads with a maximum cover of 2.7 metres. The easement shall be centered over the pipe. Where 3.0 metre wide easements cannot be attained between dwellings, “hour glass easements” will be permitted with the width of the easement decreasing between the dwellings based on the side yard setbacks permitted for the dwellings (typically 1.8 metres minimum). The easement width beyond the house envelope based on minimum front and rear yard setbacks shall be the standard 3.0 metre width.

For leads being constructed with cover deeper than 2.7 metres, the easement widths shall be increased based on consultation with the Town.

All rear yard catchbasin easements shall comply with the requirements of Section 23.5.

54.2 Storm, Sanitary Sewer and Watermain Easements

Ideally easements between adjacent lots shall be located on one side of the common lot line. Pipes shall generally be centered on the easement for easements containing one pipe. Easements straddling lots lines may be permitted if deemed appropriate by the Town. The minimum width of all easements shall be determined in consultation with the Town.

All pipes with a diameter of less than 900 mm constructed within easements between side lot lines shall be concrete encased as set out in Section 54.3. All pipes 900 mm or larger in diameter constructed between side lot lines shall be increased in strength by one class from that required based on the earth loading.

The bearing capacity of native soils must be preserved for all pipes being constructed between proposed buildings. This shall be achieved by:

- Extending the building foundations to the depth of the underside of pipe adjacent to the building.
- Placing the pipe in a sleeve constructed by tunneling.
- Installing the pipe by vertical trenching with steel sheeting left in place and cut off 0.3 metres above the building footing. The depth of the steel sheeting below the pipe invert is to be determined by a Geotechnical Engineer. Sufficient struts are to be left in place to ensure that the steel sheeting does not move during the backfilling operation.

The trench excavation and reinstatement or tunneling operation is to be monitored by a Geotechnical Engineer and certification will be required that the soils have the required bearing capacity to support the building being proposed adjacent to the pipe installation.

54.3 Concrete Encasement

Concrete encasement shall have a square cross-section with a concrete thickness of not less than 0.150 metres. The concrete shall be 15 MPa. strength and vibrated in place.

54.4 Pipes Constructed in Sleeves

In lieu of concrete encasement of pipes, the Town will consider allowing pipes to be constructed in steel sleeves. The specific instances where this will be permitted along with the detailed requirements must be determined in consultation with the Town.



Town of
East Gwillimbury

APPENDIX 1

LIST OF ACCEPTABLE MATERIALS

Town of East Gwillimbury
Engineering Standards and Design Criteria

September 2012

APPENDIX 1 – LIST OF ACCEPTABLE MATERIALS

Table of Contents

1.0	STORM SEWERS	1
2.0	SANITARY SEWERS.....	1
3.0	STORM AND SANITARY LATERALS	2
4.0	WATERMAIN AND APPURTENANCES	2

APPENDIX 1 – LIST OF ACCEPTABLE MATERIALS

1.0 STORM SEWERS

Storm Sewer mains shall be Concrete or PVC (Polyvinyl Chloride) plastic pipe. PVC plastic pipe will be permitted for storm sewers 450 mm in diameter and smaller. All storm sewer mains over 450 mm diameter shall be constructed with reinforced concrete pipe.

PVC pipe and fittings shall conform to CSA Specification B182.1 or B182.2, or latest revisions thereof. Dimension ratio (DR) of PVC sewer pipe shall be 35.

Concrete pipe shall conform to the requirements of CSA Specification A257-M 1982 for the classes shown below:

- a) Non-reinforced Concrete Pipe, CSA Standard A257.1 Class 1, 2, and 3.
- b) Reinforced Concrete Pipe, CSA Standard A257.2 Strength Class 50-D, 65-D, 100-D and 140-D.

Watertight bell and spigot connections will be required for all pipe joints.

Catchbasin Leads

Catchbasin leads shall be constructed with Concrete or PVC SDR 35 pipe.

Concrete pipe shall conform to the requirements of CSA Specification A257-M 1982 for the classes shown below:

- a) Non-reinforced Concrete Pipe, CSA Standard A257.1 Class 1, 2, and 3.
- b) Reinforced Concrete Pipe, CSA Standard A257.2 Strength Class 50-D, 65-D, 100-D and 140-D.

PVC pipe shall conform to the requirements of CSA Specification CSA B182.4.

Watertight bell and spigot connections will be required for all pipe joints.

2.0 SANITARY SEWERS

Sanitary sewer shall be constructed of reinforced concrete pipe or PVC pipe.

The type and classification shall be clearly indicated on all profile drawings on each sewer length.

PVC pipe shall only be used on sanitary sewers up to and including 450 mm in diameter and shall conform to CSA Specification B182.1 or B182.2, or latest revisions thereof. Dimension ratio (DR) of PVC sewer pipe shall be 35.

Reinforced concrete shall be used for sewers 525 mm diameter and larger and shall be steel reinforced and conform to CSA Specification A275.2, latest revision thereof, Class 50-D, 65-D, 100-D, or 140-D as required.

3.0 STORM AND SANITARY LATERALS

Sanitary

Sanitary laterals shall be 125 mm PVC Pipe, green in colour conforming to CSA Specification B182.1 or B182.2, or latest versions thereof.

Storm

Storm laterals shall be 150 mm PVC Pipe, white in colour conforming to CSA Specification B182.1 or B182.2, or latest revisions thereof.

Dimension ratio (DR) of PVC lateral pipe shall not exceed 28.

4.0 WATERMAIN AND APPURTENANCES

Watermain pipe up to and including 300 mm in diameter shall be PVC manufactured in accordance with the latest edition of AWWA C900. Minimum Class 150 (DR 18) shall be used.

Fittings

Allowable watermain fittings are as follows:

- a) Cast iron, cement lined and manufactured in accordance with the latest edition of AWWA C907 with mechanical joint ends.
- b) PVC manufactured in accordance with the latest edition of AWWA C900.

Brass Fittings

All brass components in any fittings shall be lead free.

Service Connections

All domestic water services shall be Type 'K' Copper.

Fire Hydrants

Hydrants shall be Canada Valve **only** and are to be equipped with one (1) 100 mm pumper port with manufacturer's "Storz" nozzle facing the street. The side ports shall be 65 mm diameter.

Hydrants are to be supplied with a hose nozzle cap chain and S-hook and are to be painted "Chrome" yellow.

All hydrants shall be fitted with anti-tampering devices of a type required by the Town.

Valves

All valves shall be resilient wedge gate valves as approved by the Town. They shall have a non-rising stem and a 50 mm square operating nut opening counter-clockwise.



Town of
East Gwillimbury

APPENDIX 2

STANDARD DRAWINGS

Town of East Gwillimbury
Engineering Standards and Design Criteria

September 2012

APPENDIX 2 – STANDARDS DRAWINGS

Table of Contents

18.0 metre Right-of-Way, Local Road
20.0 metre Right-of-Way, Residential Road
22.0 metre Right-of-Way, Residential Road
26.0 metre Right-of-Way, Collector Road
22.0 metre Right-of-Way, Collector Road with Turning Lane
Typical Utility Base Pole & Streetlight Fixture
Horizontal Control Monument
Typical Rear Lot Catchbasin Frame & Grate Detail
Residential Service Connection Layout
Fire & Commercial Service Valve Chamber
Typical Residential Water Meter Installation
Watermain Sample Station Installation Detail
Watermain Automatic Flushing Unit
Water Testing & Sampling Detail

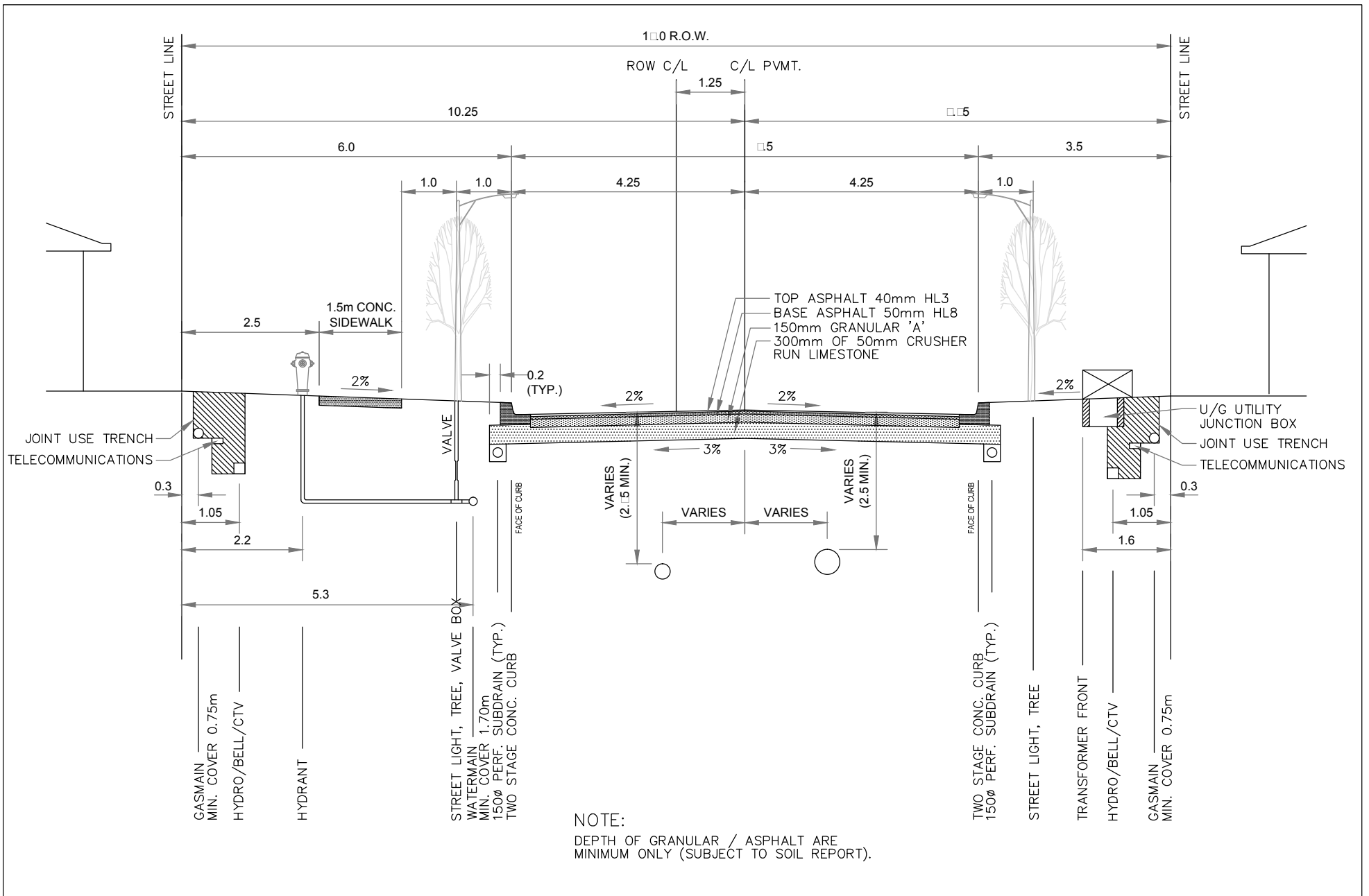

TOWN OF EAST GWILLIMBURY STANDARD DRAWING

18.0m RIGHT OF WAY
LOCAL ROAD

NO.	REVISION	DATE	BY
1	ISSUED FOR REVIEW	2012/07/02	K.B.



Town of
East Gwillimbury
ENGINEERING DEPARTMENT

DRAWN: K.B. APPROVED: D.A. SCALE: N.T.S. DATE: JUNE, 2012

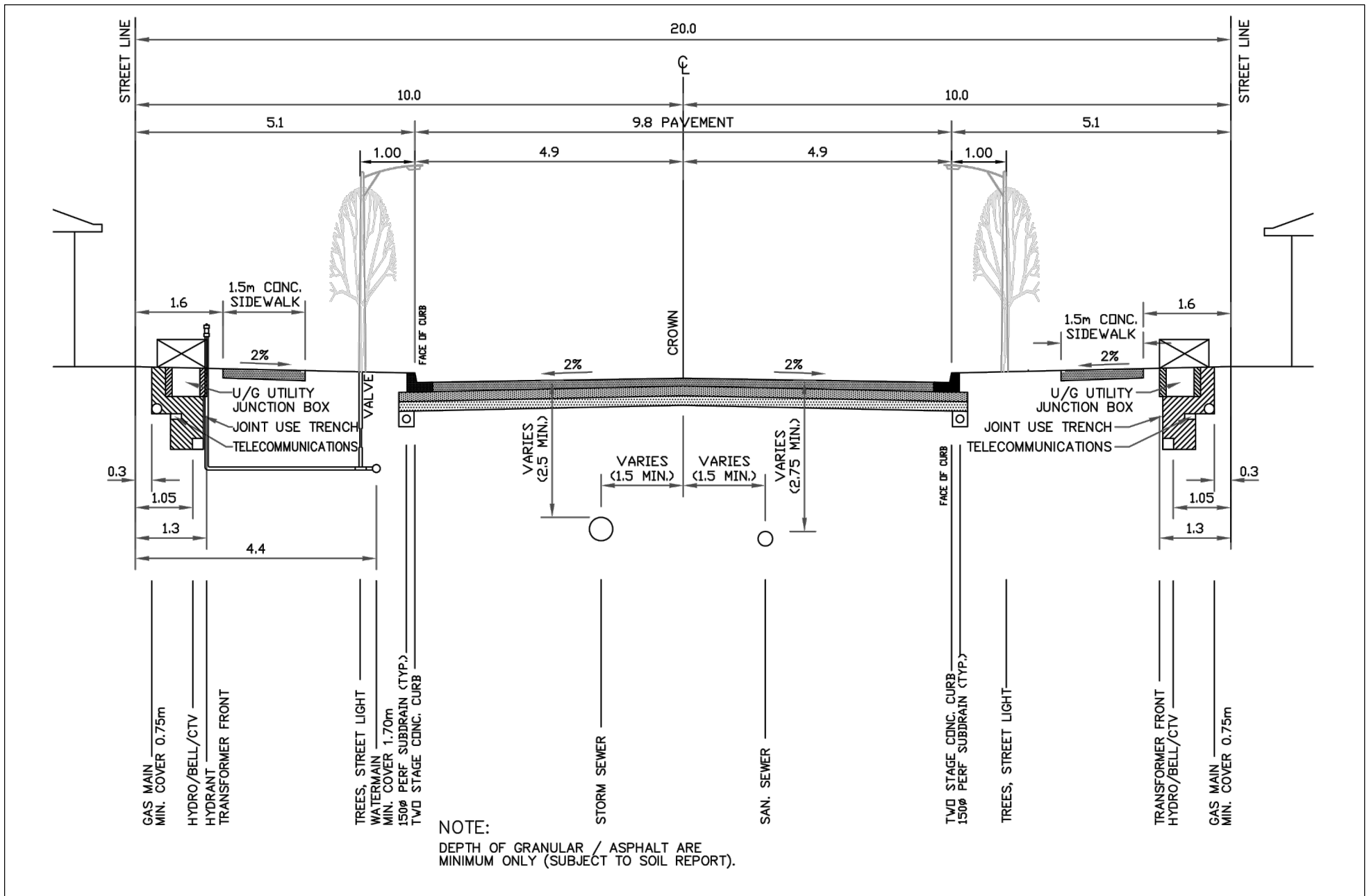

TOWN OF EAST GWILLIMBURY STANDARD DRAWING

20.0m RIGHT OF WAY
RESIDENTIAL ROAD

NO.	REVISION	DATE	BY
1	ISSUED FOR REVIEW	2012/07/02	K.B.

Town of
East Gwillimbury
ENGINEERING DEPARTMENT

DRAWN: K.B.	APPROVED: D.A.	SCALE: N.T.S.	DATE: JUNE, 2012
----------------	-------------------	------------------	---------------------

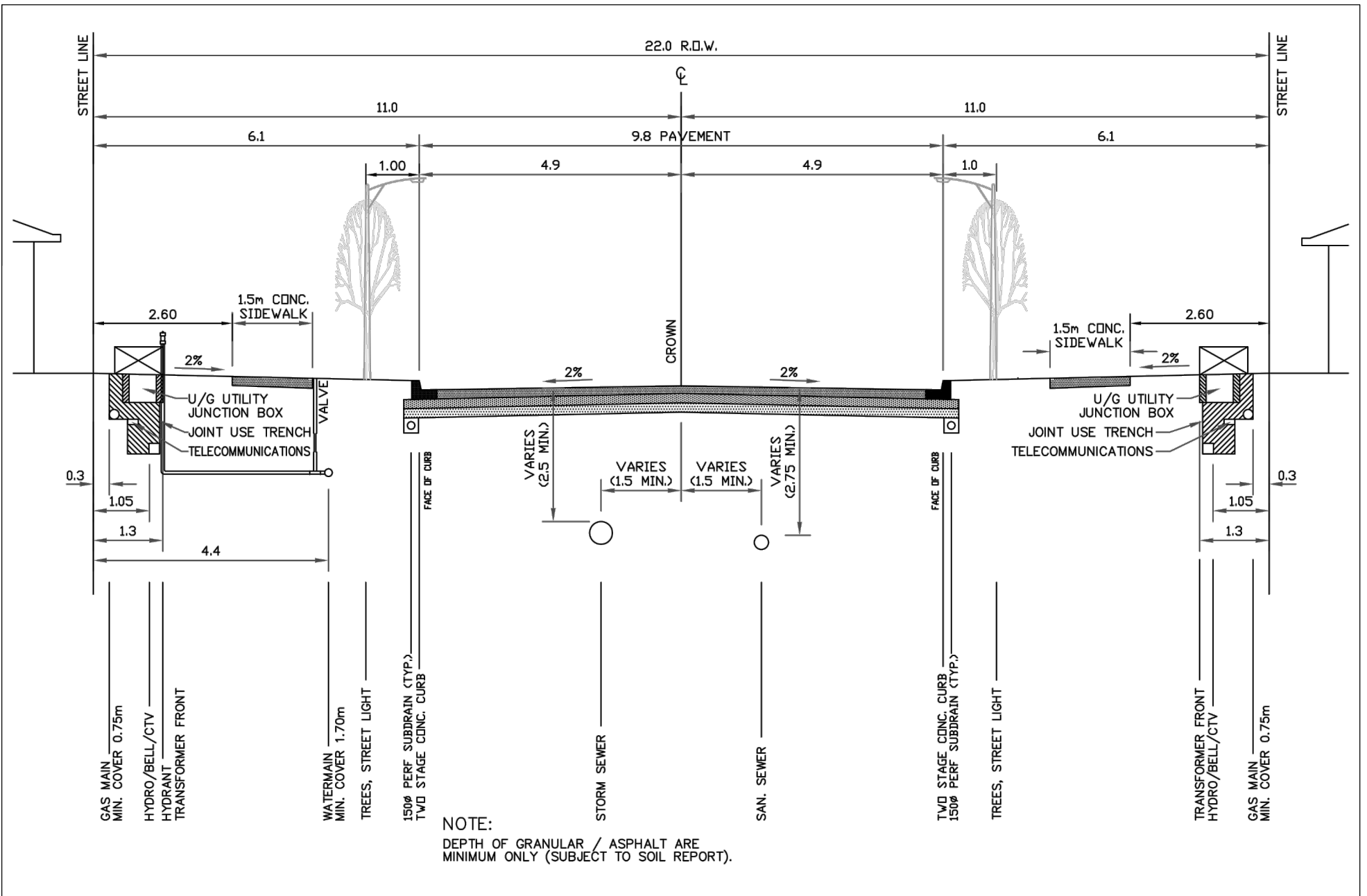

TOWN OF EAST GWILLIMBURY STANDARD DRAWING

22.0m RIGHT OF WAY
RESIDENTIAL ROAD

NO.	REVISION	DATE	BY
1	ISSUED FOR REVIEW	2012/07/02	K.B.

Town of East Gwillimbury
ENGINEERING DEPARTMENT

Our town. Our future.

DRAWN: K.B. APPROVED: D.A. SCALE: N.T.S. DATE: JUNE, 2012

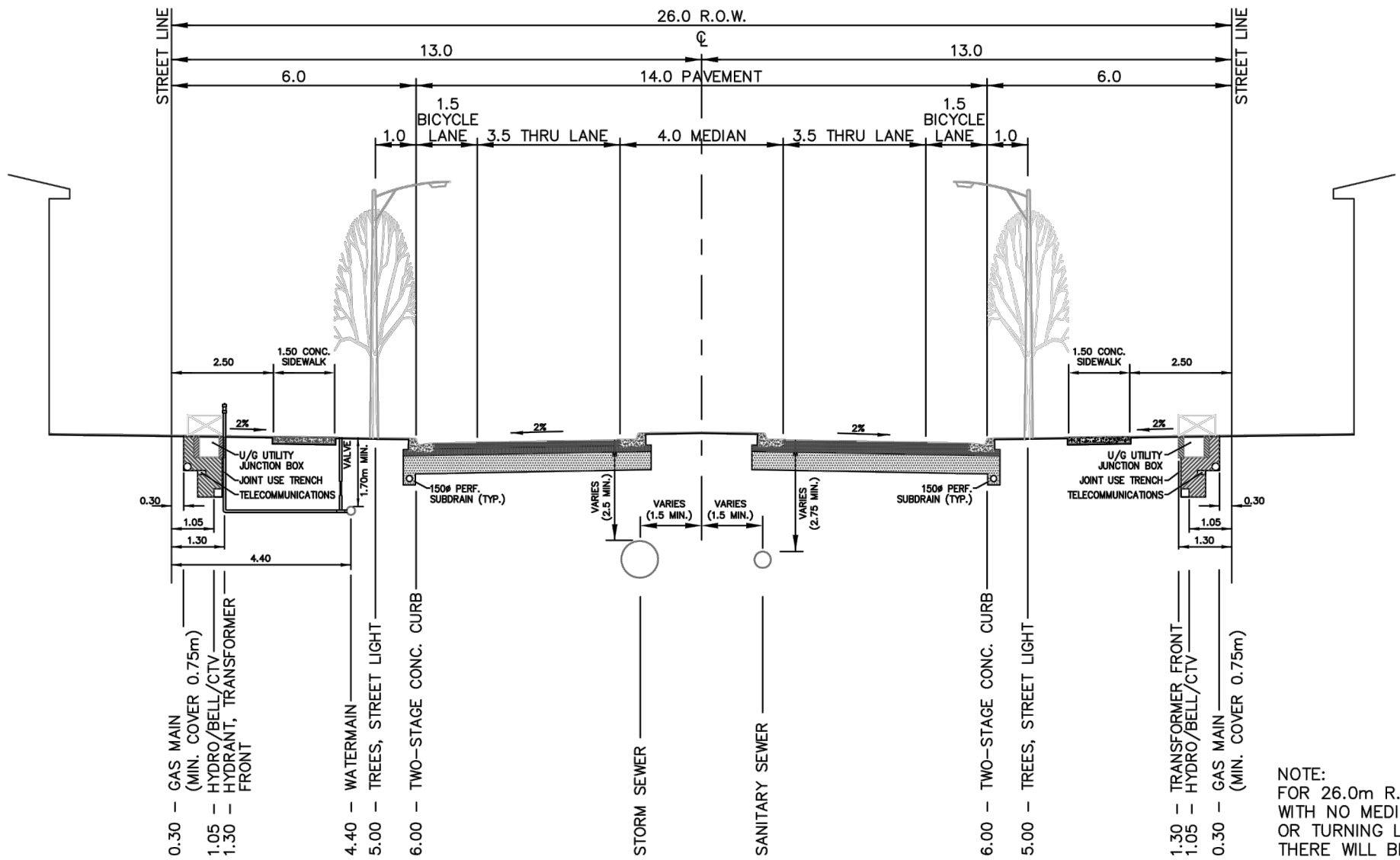

- 0.30 - GAS MAIN (MIN. COVER 0.75m)
- 1.05 - HYDRO/BELL/CTV
- 1.30 - HYDRANT, TRANSFORMER FRONT
- 4.40 - U/G UTILITY JUNCTION BOX, JOINT USE TRENCH, TELECOMMUNICATIONS
- 1.70m MIN. - VALVE
- 4.40 - WATERMAIN
- 5.00 - TREES, STREET LIGHT
- 6.00 - TWO-STAGE CONC. CURB
- 150# PERF. SUBDRAIN (TYP.)
- VARIES (2.5 MIN.)
- VARIES (1.5 MIN.)
- VARIES (1.5 MIN.)
- VARIES (2.75 MIN.)
- 150# PERF. SUBDRAIN (TYP.)
- 6.00 - TWO-STAGE CONC. CURB
- 5.00 - TREES, STREET LIGHT
- 1.30 - TRANSFORMER FRONT
- 1.05 - HYDRO/BELL/CTV
- 0.30 - GAS MAIN (MIN. COVER 0.75m)

NOTE:
 FOR 26.0m R.O.W.s
 WITH NO MEDIAN
 OR TURNING LANE,
 THERE WILL BE AN
 ADDITIONAL 2.0m
 BOULEVARD ON
 THE OUTSIDE OF
 EACH SIDE

TOWN OF EAST GWILLIMBURY STANDARD DRAWING

26.0m RIGHT OF WAY
 COLLECTOR ROAD

NO.	REVISION	DATE	BY
1	ISSUED FOR REVIEW	2012/07/02	K.B.

Town of
East Gwillimbury
 ENGINEERING DEPARTMENT

Our town. Our future.

DRAWN: K.B. APPROVED: D.A. SCALE: N.T.S. DATE: JUNE, 2012

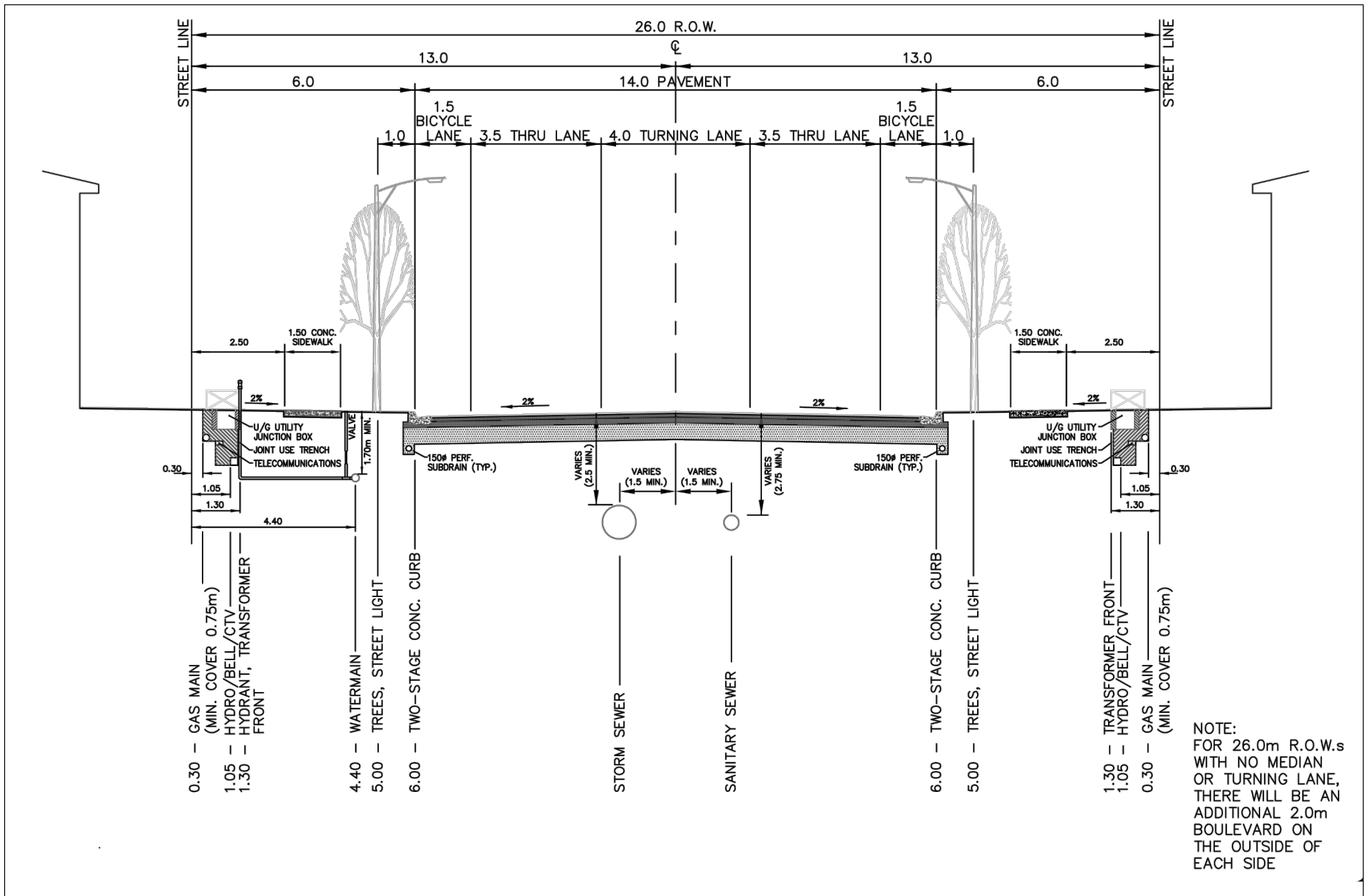

TOWN OF EAST GWILLIMBURY STANDARD DRAWING

26.0m RIGHT OF WAY
 COLLECTOR ROAD W. TURNING LANE

NO.	REVISION	DATE	BY
1	ISSUED FOR REVIEW	2012/07/02	K.B.

Town of
East Gwillimbury
 ENGINEERING DEPARTMENT

DRAWN: K.B. APPROVED: D.A. SCALE: N.T.S. DATE: JUNE, 2012

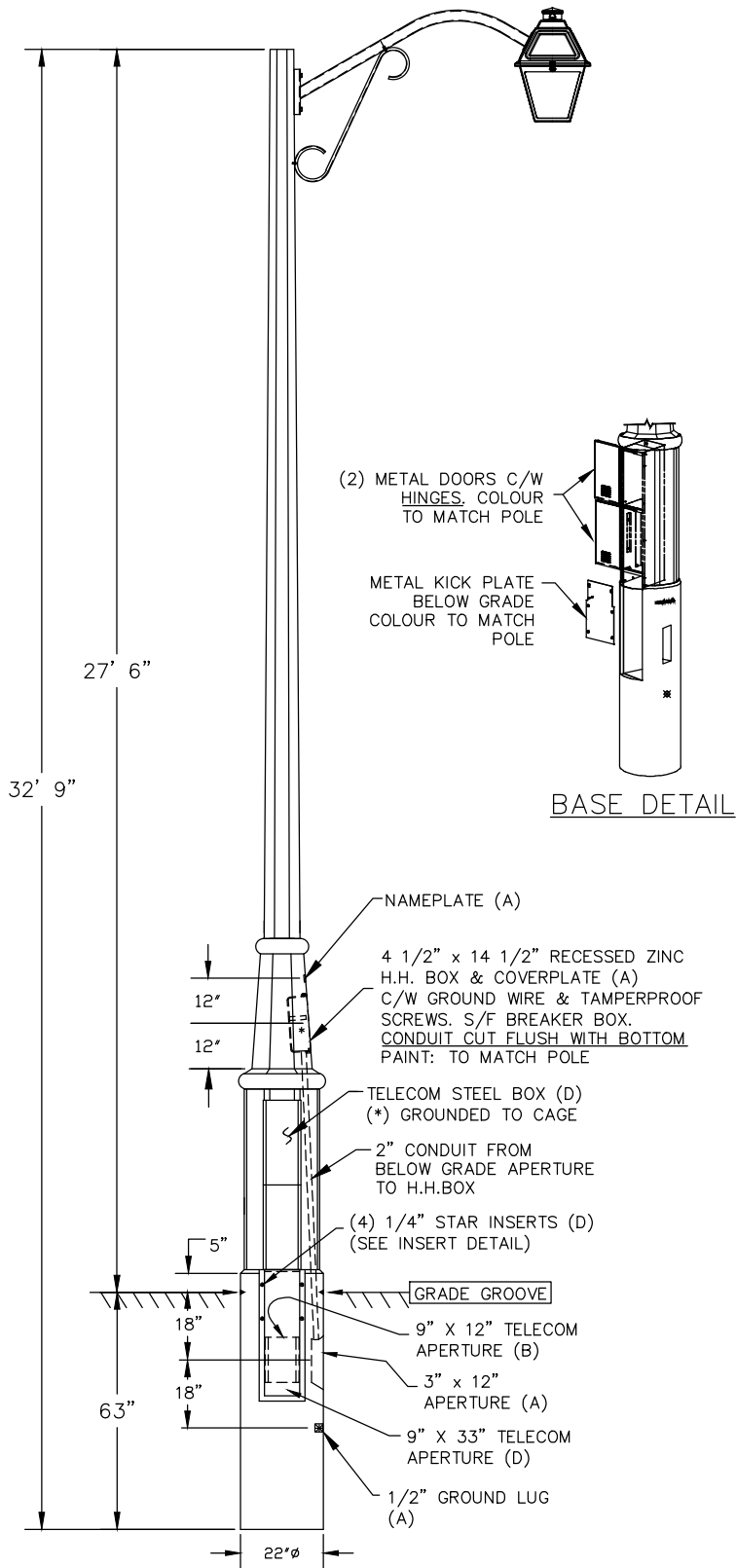

NOTES:

1. POLE TO BE PRE-STRESSED CONCRETE BY STRESSCRETE GROUP OR APPROVED EQUIVALENT
2. LUMINAIRE TO BE EMPRESS LUMINAIRE BY STRESSCRETE GROUP OR APPROVED EQUIVALENT
3. SUPPORT ARM TO BE VICTORIAN SCROLL ARM BY STRESSCRETE GROUP OR APPROVED EQUIVALENT
4. POLE SECTION TO BE OCTAGONAL, MIDNIGHT LACE COLOUR (OR A.E.) C/W ETCHED FINISH
5. POLE COATING TO BE 2 COATS ACRYLIC, FULL LENGTH OF POLE
6. METAL COMPONENTS (COVER PLATE, DOOR, KICK PLATE) TO BE PAINTED TEXTURED BLACK
7. BURIAL DEPTH SPECIFIED IS FOR REFERENCE ONLY. ACTUAL BURIAL DEPTH FOR PROPER SUPPORT OF STRUCTURE TO BE DETERMINED BY COMPETENT PROFESSIONAL.

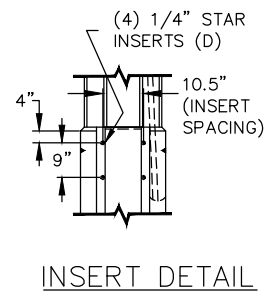
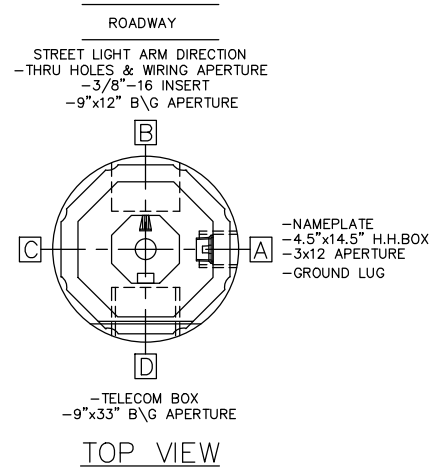

TOWN OF EAST GWILLIMBURY STANDARD DRAWING	NO.	REVISION	DATE	BY		
	1	ISSUED FOR REVIEW	2012/08/21	K.B.		
TYPICAL UTILITY BASE POLE & STREETLIGHT FIXTURE					DRAWN:	K.B.
					APPROVED:	D.A.

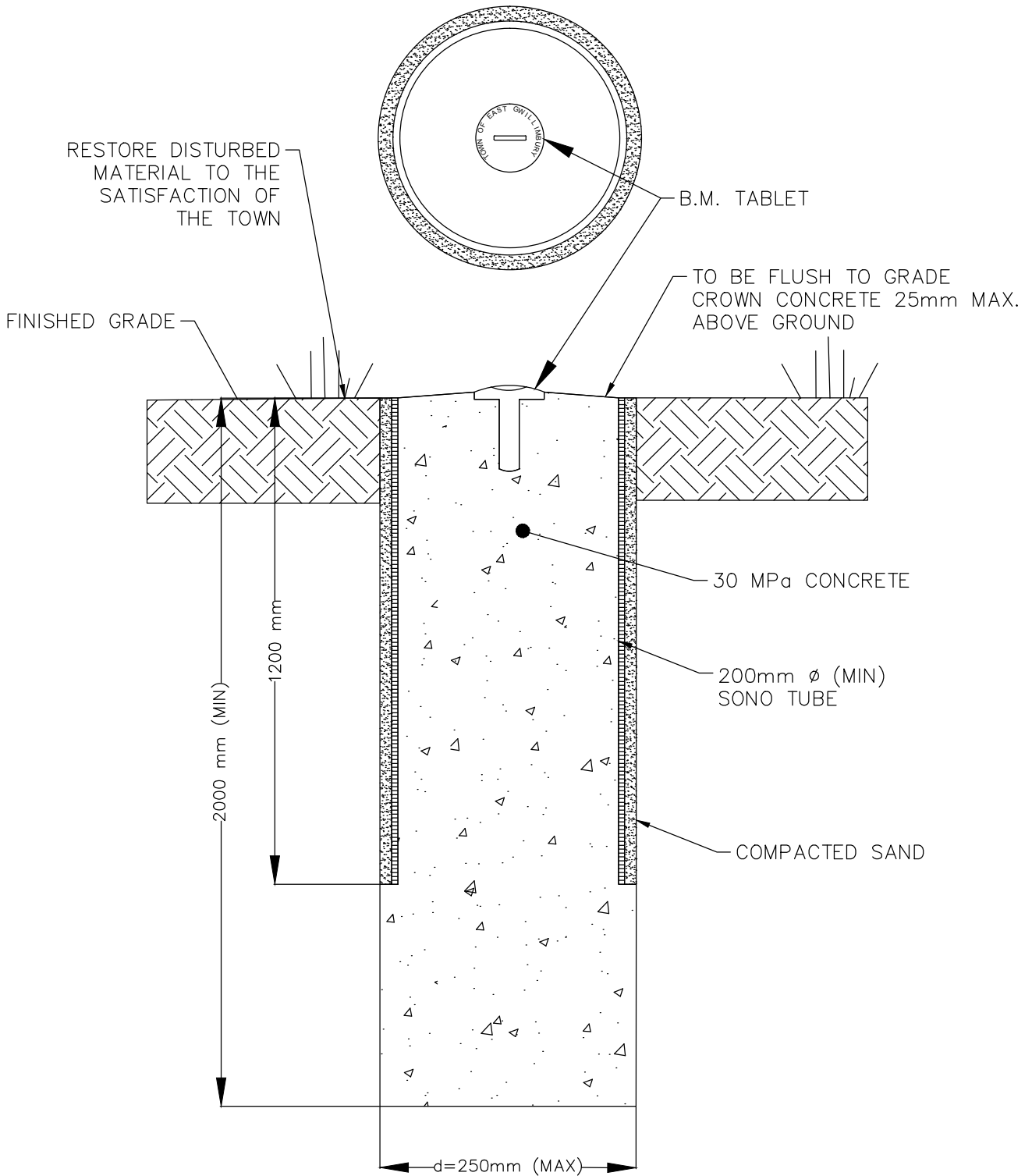

TOWN OF EAST GWILLIMBURY STANDARD DRAWING	NO.	REVISION	DATE	BY
	1	ISSUED FOR REVIEW	2012/07/02	K.B.
HORIZONTAL CONTROL MONUMENT				
DRAWN: K.B.		APPROVED: D.A.	SCALE: N.T.S.	DATE: JUNE, 2012



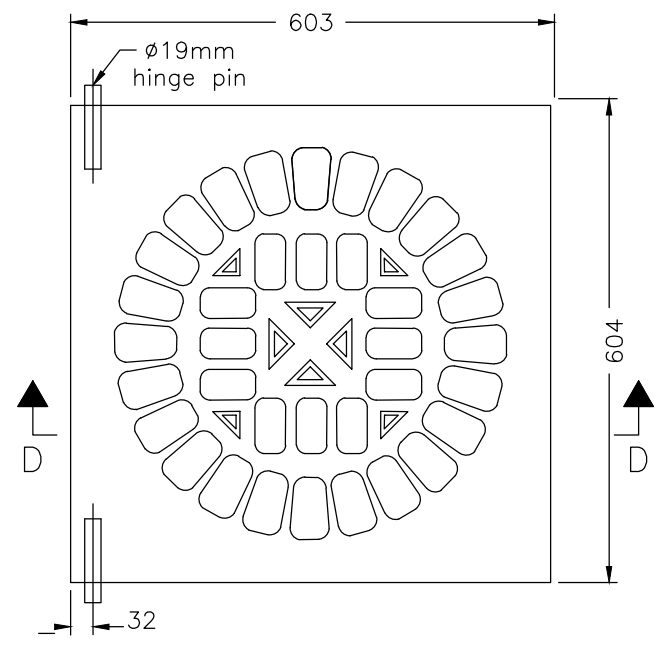
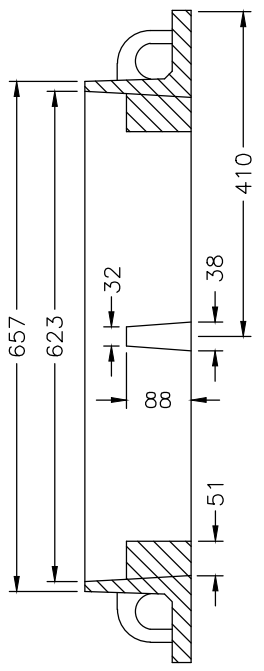
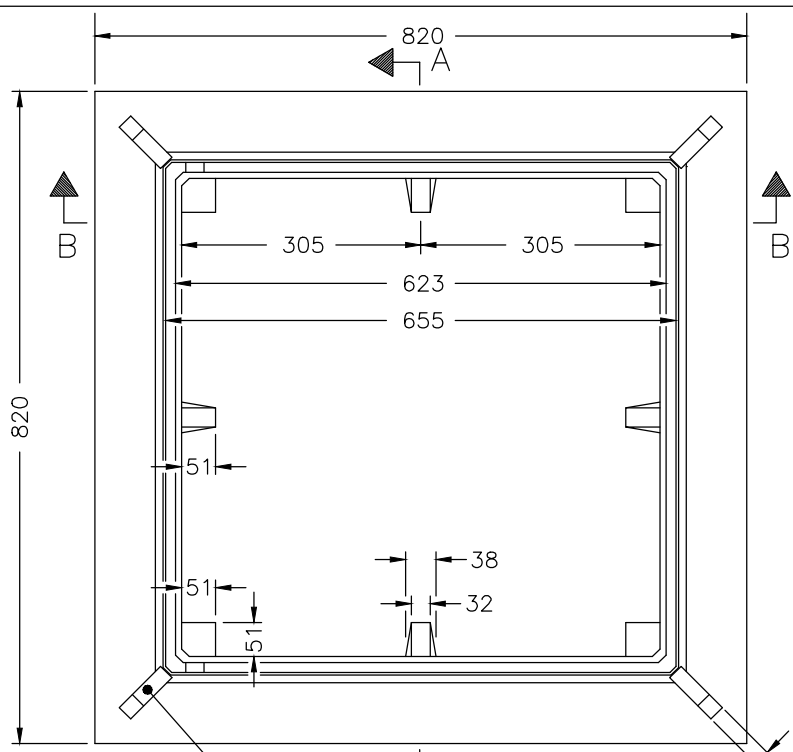

Hoisting hook rib, Typ, OPSD 400.001

FRAME PLAN

SECTION A-A

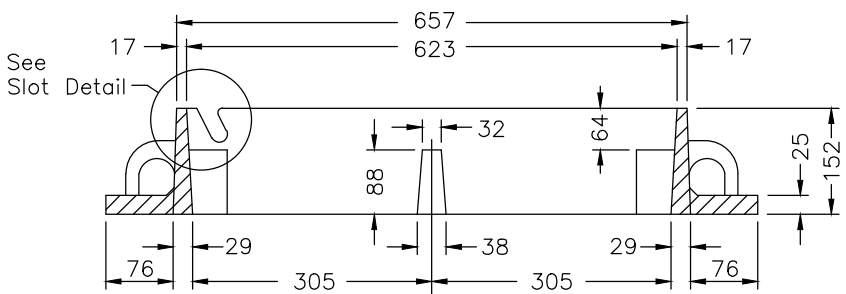

SECTION B-B

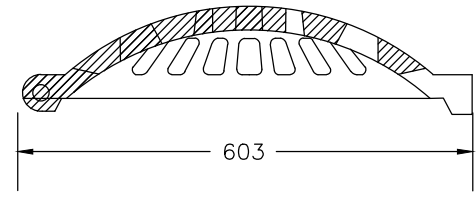

SECTION D-D

See Slot Detail

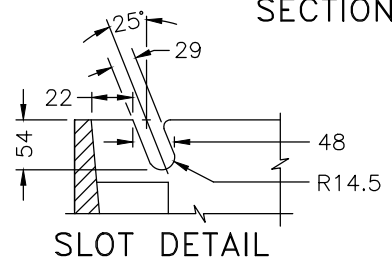

SLOT DETAIL

Notes:

1. All dimensions are in millimetres unless otherwise shown.
2. Grate to be Bibby St. Croix JW-105B or approved equivalent
3. Frame per OPSD 400.120 or approved equivalent

TOWN OF EAST GWILLIMBURY STANDARD DRAWING		NO.	REVISION	DATE	BY
TYPICAL REAR LOT CATCHBASIN FRAME & GRATE DETAIL		1	ISSUED FOR REVIEW	2012/07/02	K.B.



Town of East Gwillimbury
ENGINEERING DEPARTMENT

DRAWN: K.B.	APPROVED: D.A.	SCALE: N.T.S.	DATE: JULY, 2012
-----------------------	--------------------------	-------------------------	----------------------------

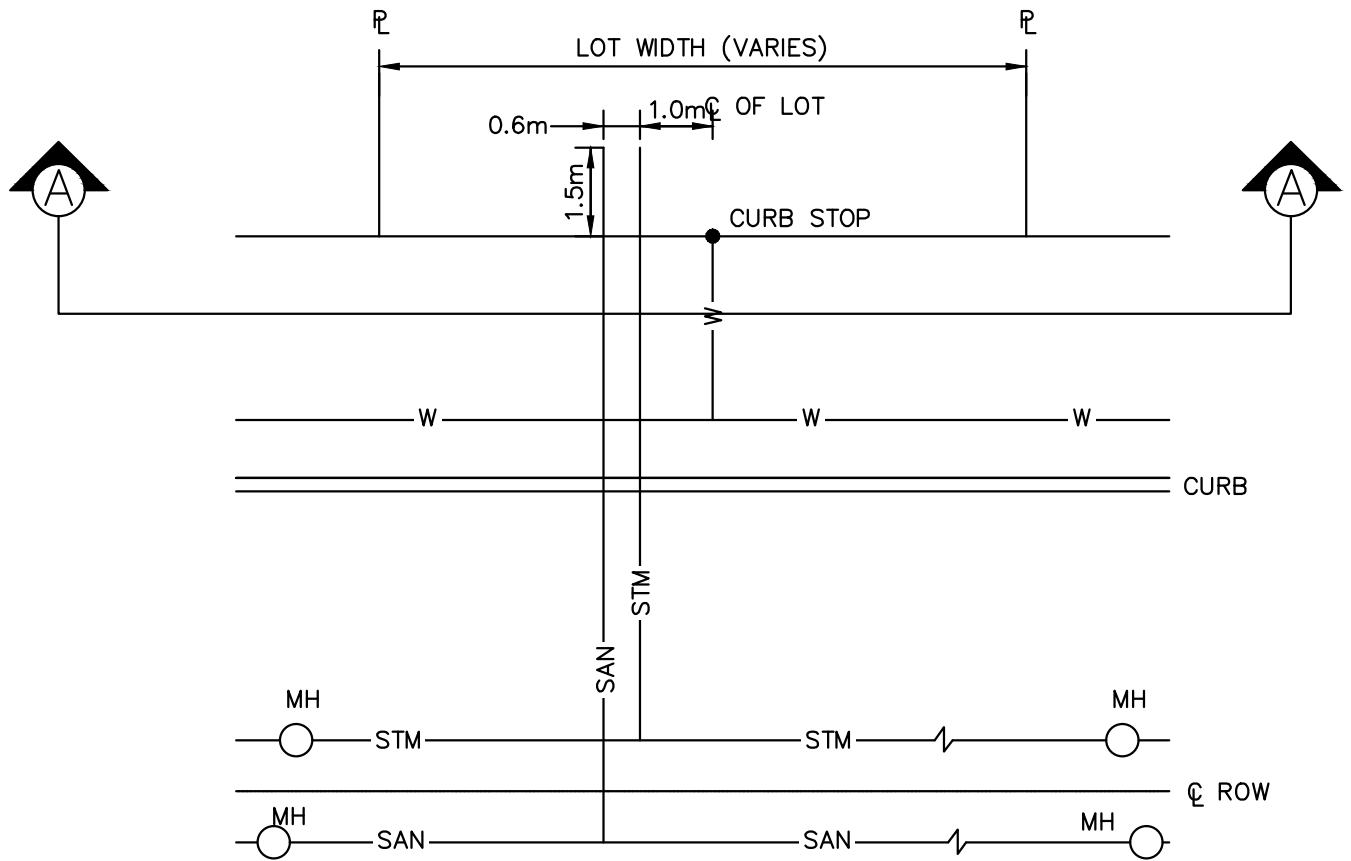

PLAN VIEW
N.T.S.

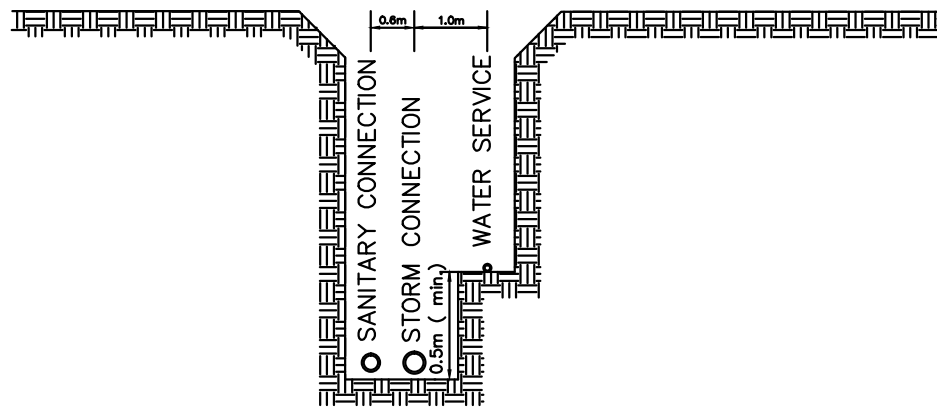

SECTION A - A
N.T.S.

NOTES:

1. ALL EXCAVATIONS MUST BE CARRIED OUT ACCORDING TO THE OCCUPATIONAL HEALTH AND SAFETY ACT, R.S.O. 1990 c.o.1 AND REGULATIONS FOR CONSTRUCTION PROJECTS (O.Reg. 213/91)
2. ALL TRENCHES TO BE BACKFILLED TO TOWN OF EAST GWILLIMBURY STANDARDS AND COMPACTED TO 95% STANDARD PROCTOR DENSITY (S.P.D.).

TOWN OF EAST GWILLIMBURY STANDARD DRAWING	NO.	REVISION	DATE	BY	 East Gwillimbury ENGINEERING DEPARTMENT
	1	ISSUED FOR REVIEW	2012/07/02	K.B.	
RESIDENTIAL SERVICE CONNECTION LAYOUT					DRAWN: K.B. APPROVED: D.A. SCALE: N.T.S. DATE: JUNE, 2012

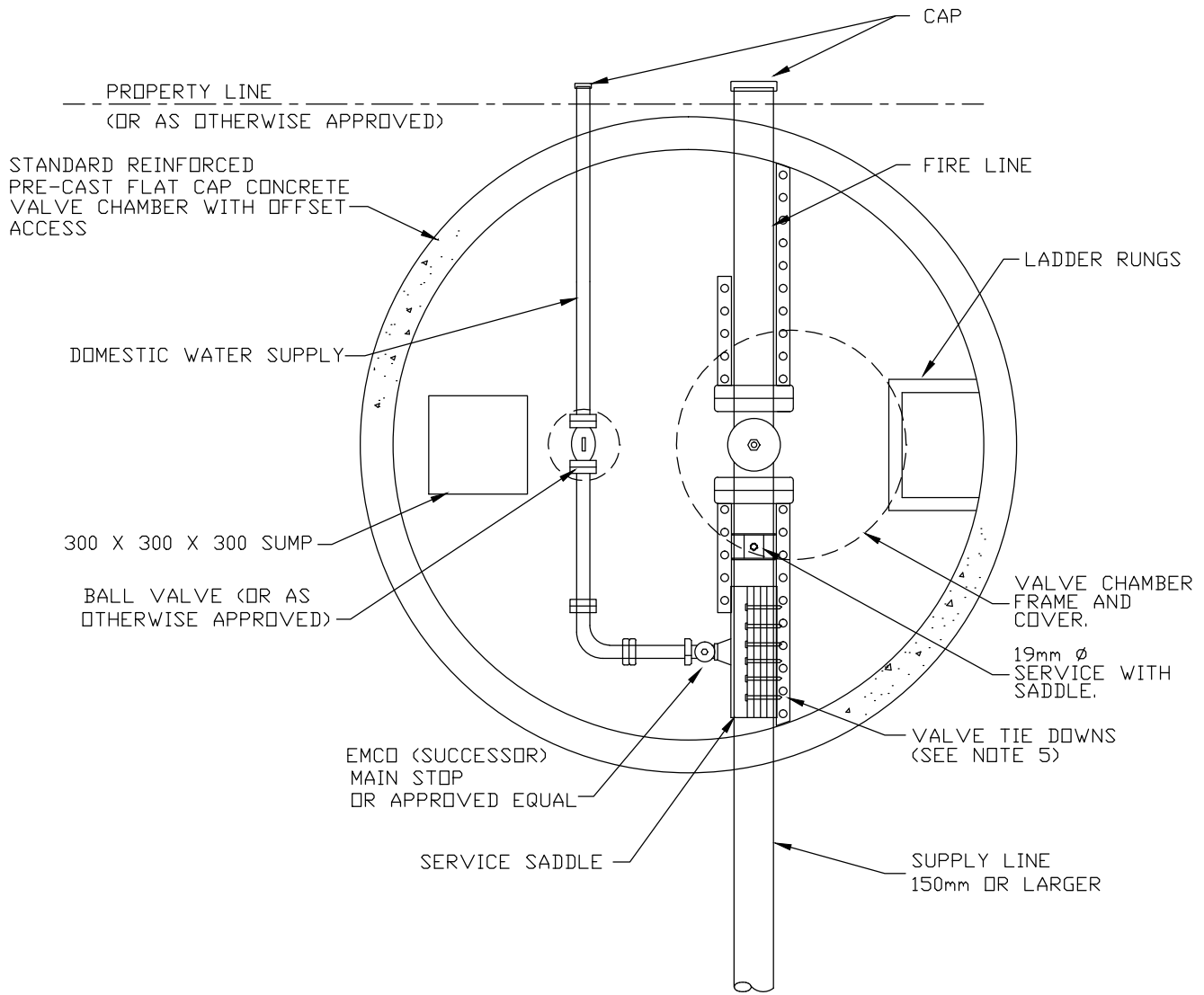

NOTES:

1. VALVE CHAMBER EXCAVATION TO BE BACKFILLED WITH GRANULAR 'B'.
2. CHAMBER NOT TO BE LOCATED IN DRIVEWAY.
3. CAP TO BE DRILLED FOR SLIDING VALVE BOX TO BE SET AT GROUND ELEVATION. VALVE BOX TO ALIGN WITH VALVE BELOW GRADE.
4. ALL PIPES PASSING THROUGH PRE-CAST CHAMBER WALLS TO BE SEALED WITH NON-SHRINKABLE MORTAR
5. ALL TIE DOWNS TO BE CADMIUM OR ZINC COATED
6. THE FINISHED ELEVATION OF VALVE BOXES AND CHAMBER MANHOLES SHALL BE SET FLUSH WITH FINISHED GRADE
7. ALL VALVES TO BE FLANGE TYPE WITH PLAIN END ADAPTERS.
8. ALL WATER LINE SIZING TO BE CERTIFIED BY A CONSULTANT TO VERIFY ALL APPLICABLE CODES AND OR LEGISLATION HAS BEEN MET.
9. ALL ITEMS REFERENCE ARE TO CONFORM TO ALL CURRENT O.P.S.D. STANDARDS.

TOWN OF EAST GWILLIMBURY STANDARD DRAWING	NO.	REVISION	DATE	BY					
	1	ISSUED FOR REVIEW	2012/07/02	K.B.					
FIRE & COMMERCIAL SERVICE VALVE CHAMBER									

Town of
East Gwillimbury
ENGINEERING DEPARTMENT

DRAWN: K.B.	APPROVED: D.A.	SCALE: N.T.S.	DATE: JUNE, 2012
----------------	-------------------	------------------	---------------------

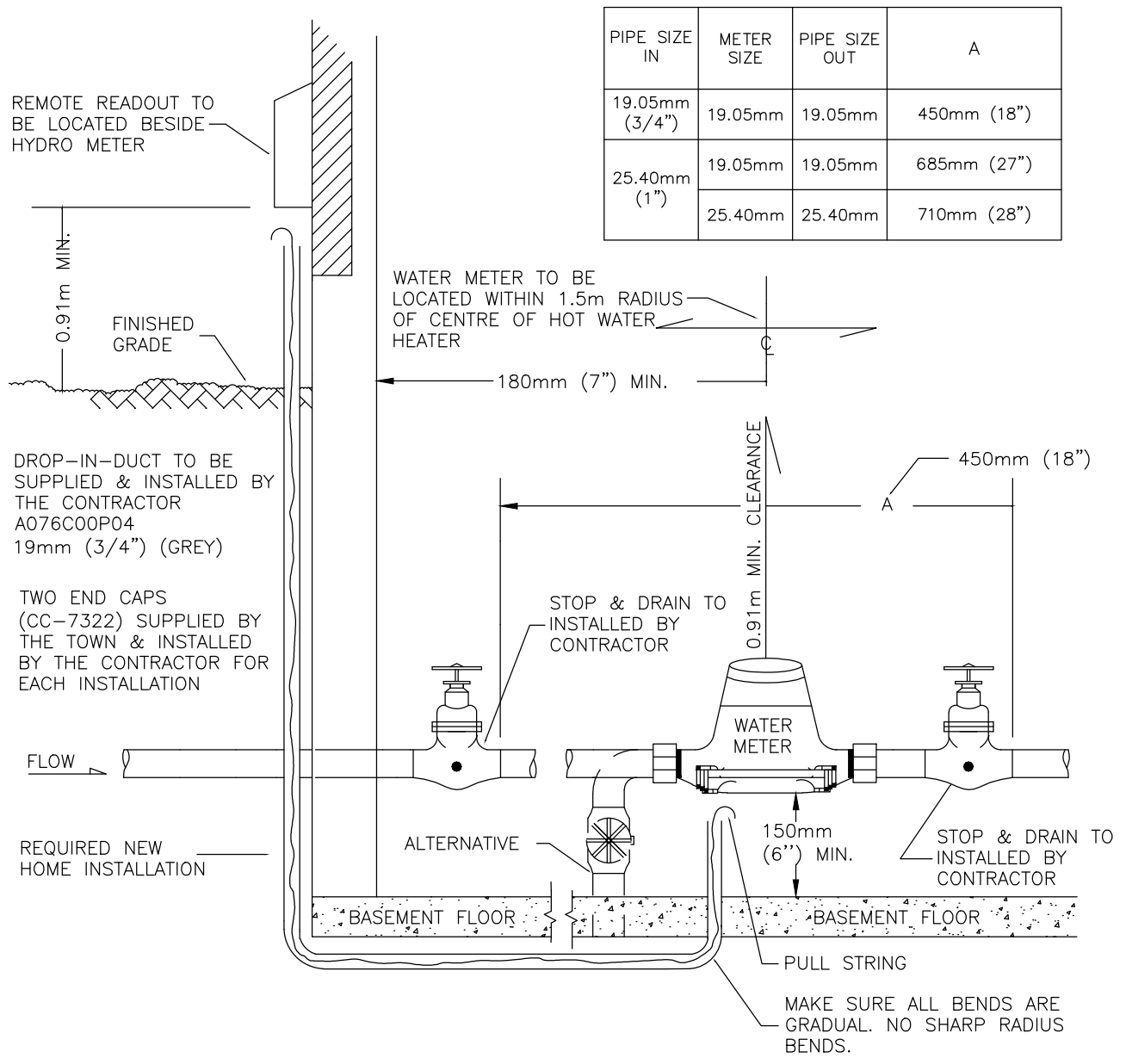

NOTES:

1. 180mm (7") MINIMUM CLEARANCE BETWEEN WALL AND C/L OF WATER METER
2. A 19mm (3.4") Ø COPPER PIPE TO BE INSTALLED HORIZONTALLY WITH A MINIMUM LENGTH OF 450mm (18") FOR THE TOWN'S WATER METER.
3. VALVES TO BE INSTALLED BY A QUALIFIED LICENSED CONTRACTOR.
4. THE TOWN SUPPLIES AND INSTALLS ALL WATER METERS.

TOWN OF EAST GWILLIMBURY STANDARD DRAWING	NO.	REVISION	DATE	BY	 East Gwillimbury ENGINEERING DEPARTMENT <small>Our town. Our future.</small>
	1	ISSUED FOR REVIEW	2012/07/02	K.B.	
TYPICAL RESIDENTIAL WATER METER INSTALLATION					DRAWN: K.B. APPROVED: D.A. SCALE: N.T.S. DATE: JUNE, 2012

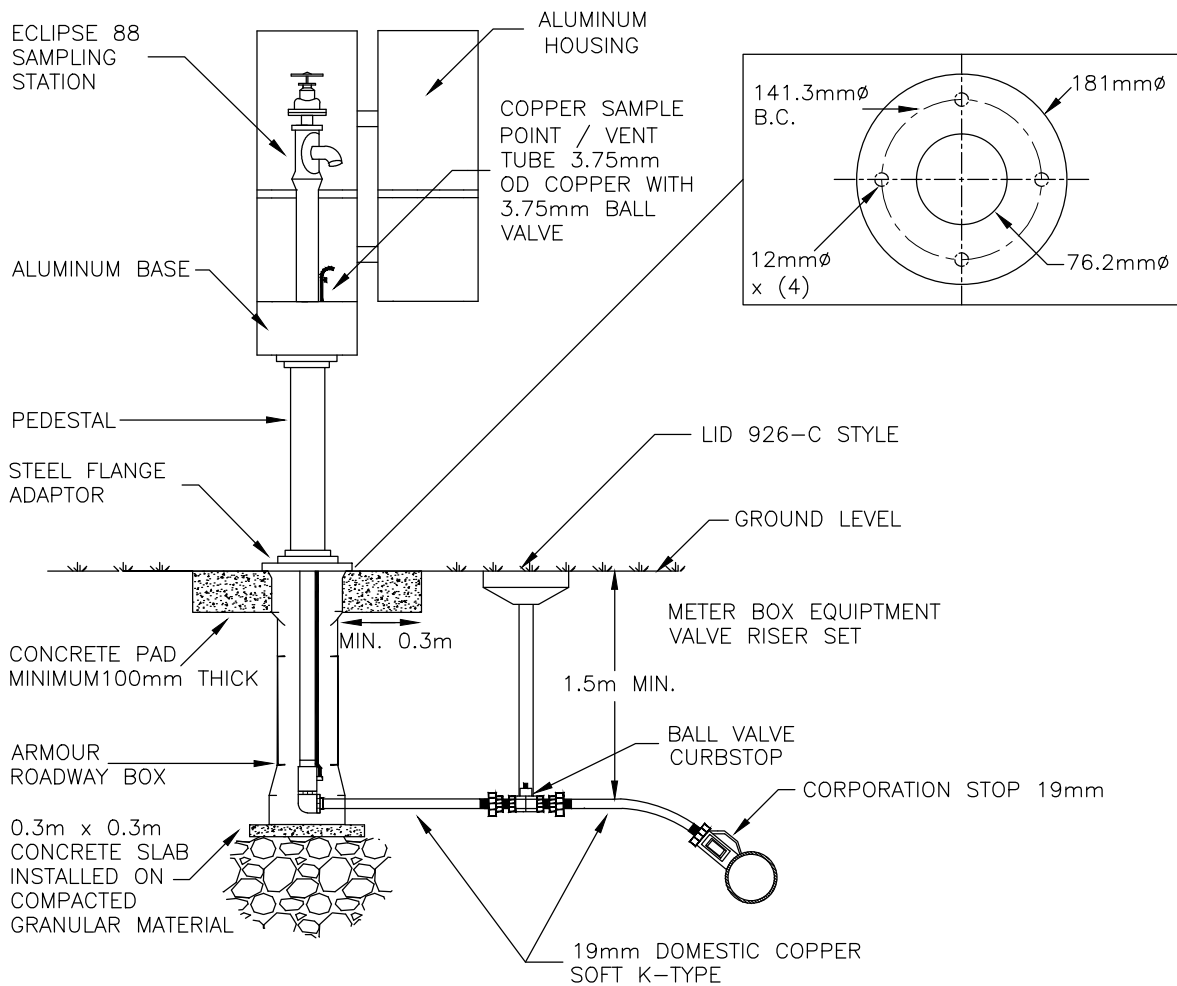

NOTES:

1. SAMPLE STATION SHALL BE KUPFERLE #88 ECLIPSE, OR APPROVED EQUIVALENT.
2. SAMPLING STATIONS SHALL BE 1.5m BELOW GROUND LEVEL, WITH A 25mm MIP INLET AND A 25mm FIP DISCHARGE.
3. A 6.35mm BENT-NOSE SAMPLING BIBB SHALL BE LOCATED BEFORE THE DISCHARGE.
4. ALL STATIONS SHALL BE ENCLOSED IN A LOCKABLE, NON-REMOVABLE ALUMINIUM CAST HOUSING. HOUSING SHALL BE ON A 762mm PEDESTAL WITH A 2.1m MOUNTING FLANGE.
5. WHEN OPENED, THE STATION SHALL REQUIRE NO KEY FOR OPERATION AND THE WATER WILL FLOW IN AN ALL BRASS WATERWAY AND BE SERVICEABLE FROM ABOVE GROUND WITH NO DIGGING.
6. A 25mm BALL VALVE WILL CONTROL THE WATER FLOW AND SHALL BE LOCATED BEFORE OR AFTER THE SAMPLING BIBB.

TOWN OF EAST GWILLIMBURY STANDARD DRAWING	NO.	REVISION	DATE	BY
	1	ISSUED FOR REVIEW	2012/07/02	K.B.
SAMPLE STATION INSTALLATION DETAIL (TYPICAL INSTALLATION USING SLEEVE KIT)				
 Town of East Gwillimbury ENGINEERING DEPARTMENT				
DRAWN:	APPROVED:	SCALE:	DATE:	
K.B.	D.A.	N.T.S.	JUNE, 2012	

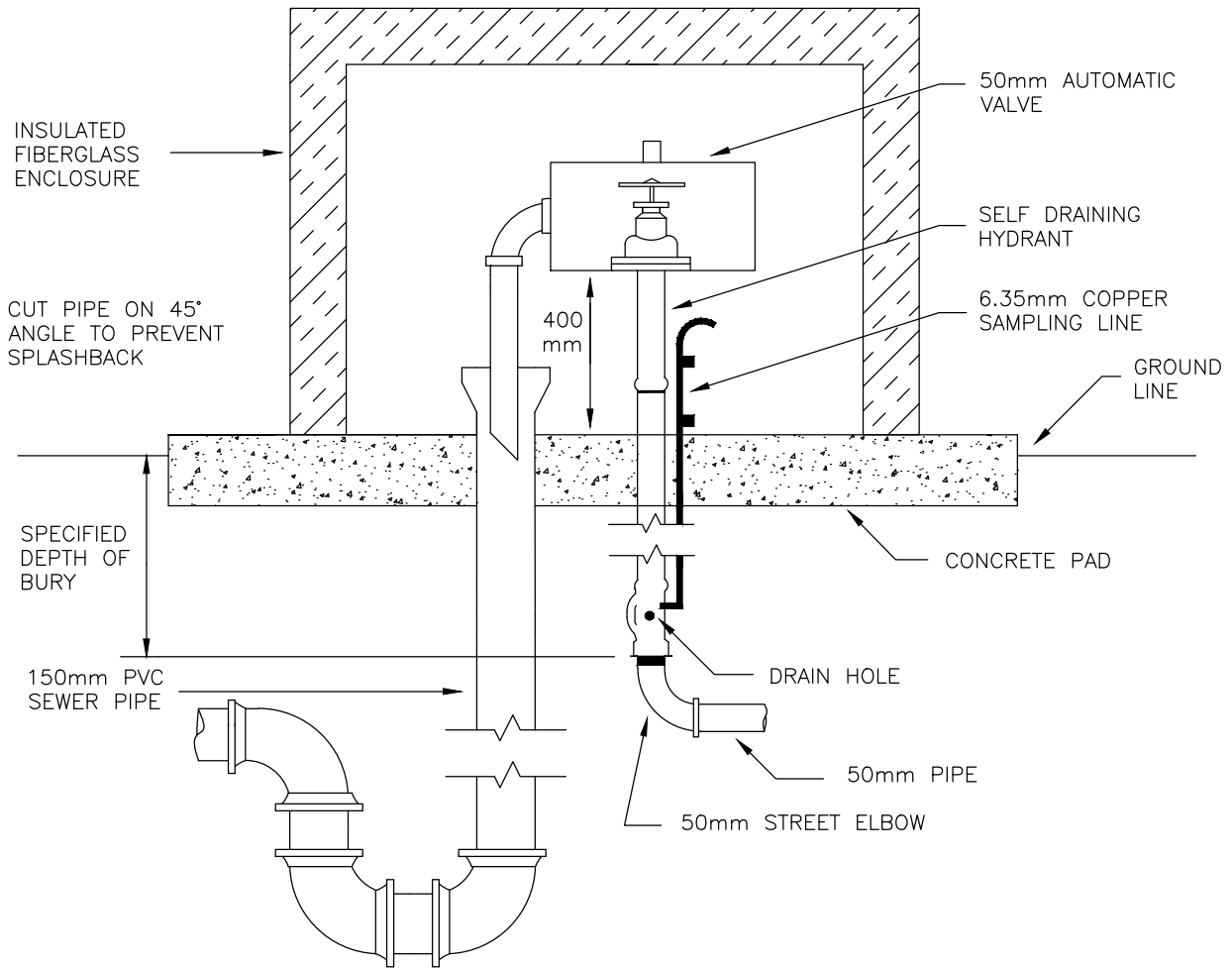

NOTES:

1. THE BLOW-OFF SHALL BE MANUFACTURED BY KUPFERLE FOUNDRY, ST. LOUIS, MO MODEL #9600TS, OR APPROVED EQUAL.
2. BLOW OFFS SHALL HAVE A 50mm F/P BRASS VERTICLE INLET LEADING INTO A SELF-DRAINING 50.8mm HYDRANT SET IN INSULATED FIBERGLASS BOXES WITH A MINIMUM PROTECTION OF R8.
3. HYDRANT TOP CAP SHALL BE 400mm ABOVE GRADE.
4. THE BLOW-OFF SHALL BE ABLE TO FLUSH AUTOMATICALLY AT CHOSEN INTERVALS USING A PORTABLE BATTERY OPERATED CONTROLLER AND A 50mm AUTOMATIC VALVE.
5. FLUSHING INTERVAL MUST BE ABLE TO BE PRE-SET ON THE CONTROLLER AND THEN DELIVERED TO SITE.
- 6, WATER SHALL OUTLET TO A 150mm STORM SEWER PIPE TO DISCHARGE WATER TO ACCEPTABLE OUTLET.
7. A MINIMUM 100mm AIR GAP MUST EXIST BETWEEN THE BLOW-OFF OUTLET AND THE SEWER PIPE.
8. ASSEMBLY MUST BE FURNISHED WITH AN ALTERNATE FLUSHING PIPE FOR MANUAL OPERATION.

TOWN OF EAST GWILLIMBURY STANDARD DRAWING	NO.	REVISION	DATE	BY	 Town of East Gwillimbury ENGINEERING DEPARTMENT
	1	ISSUED FOR REVIEW	2012/07/02	K.B.	
AUTOMATIC FLUSHING UNIT					DRAWN:
					APPROVED:
					SCALE:
					DATE:
					K.B. D.A. N.T.S. JUNE, 2012

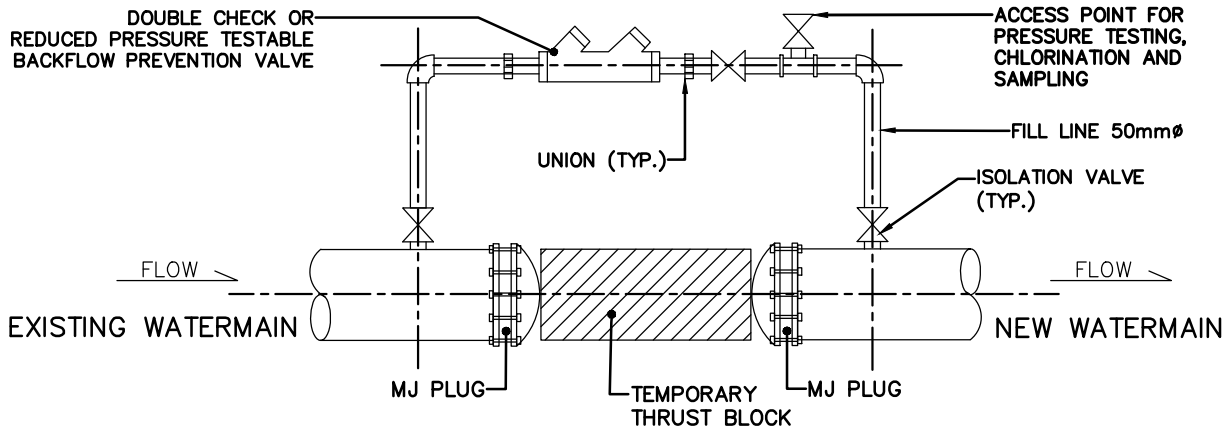

BACKFLOW PREVENTION ASSEMBLY

(FOR WATERMAIN TESTING & SAMPLING PRIOR TO COMMISSIONING)

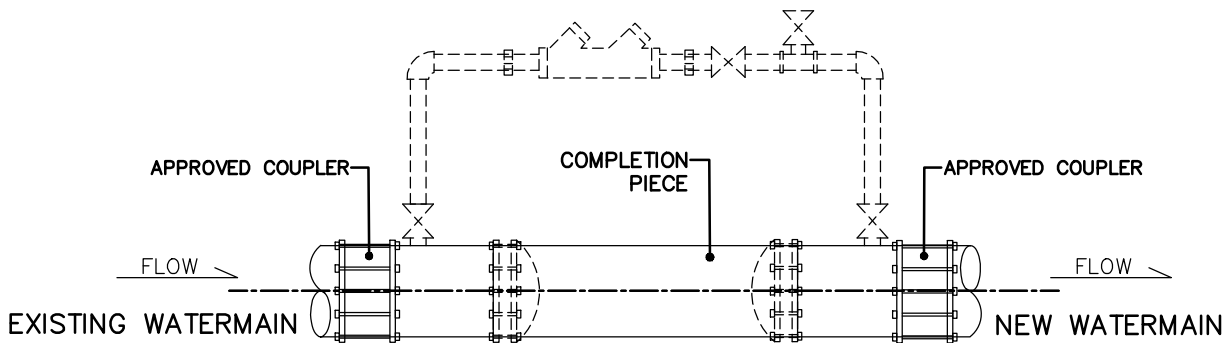

WATERMAIN COMPLETED ASSEMBLY

NOTES:

1. WATERMAIN COMMISSIONING SHALL BE IN ACCORDANCE WITH THE TOWN'S OPERATIONS & MAINTENANCE MANUAL FOR WATER DISTRIBUTION SYSTEMS
2. THE BACKFLOW PREVENTION ASSEMBLY SHALL BE REMOVED DURING WATERMAIN PRESSURE TESTS.
3. THE FINAL CONNECTION OF THE WATERMAIN SHALL BE COMPLETED ONLY AFTER AUTHORIZATION BY THE MUNICIPALITY.
4. THE WATERMAIN SHALL BE DRAINED BY CONTROLLED MEANS. SUFFICIENT TRENCH DE-WATERING CAPACITY SHALL BE USED WHEN THE EXISTING AND NEW WATERMAINS ARE DRAINED PRIOR TO THE FINAL CONNECTION TO ENSURE NO BACKFLOW INTO EITHER WATERMAIN.
5. THE WATERMAIN SHALL BE CUT BACK TO REMOVE THE TAPPING POINTS OF THE BACKFLOW ASSEMBLY.
6. ALL NEW PIPING AND APPURTENANCES PLACED IN THE CONNECTION SHALL BE NEW, UNUSED AND BE THOROUGHLY DISINFECTED WITH 1% SOLUTION OF SODIUM HYPOCHLORITE OR EQUIVALENT.
7. ON NON-METALLIC WATERMAINS, THE TRACER WIRE SHALL BE CONNECTED TO THE COUPLER ONLY IF THE COUPLER IS NOT IN CONTACT WITH A METALLIC WATERMAIN OTHERWISE TERMINATE TRACER WIRE WITH AN ANODE.
8. A PHYSICAL SEPARATION MUST BE MAINTAINED AT ALL CONNECTION POINTS OF NEW WATERMAINS TO THE EXISTING SYSTEMS UNTIL BACTERIOLOGICAL TESTS HAVE PASSED. A SAMPLING TAP MUST BE PROVIDED AT THE END OF EACH BRANCH OR STUB.
9. ONLY THE MUNICIPAL STAFF SHALL OPERATE MUNICIPAL-OWNED VALVES.
10. THIS DETAIL IS FOR SCHEMATIC INFORMATION ONLY. THE ACTUAL CONFIGURATION USED MUST SATISFY THE INTENT OF THIS DRAWING.

TOWN OF EAST GWILLIMBURY STANDARD DRAWING	NO.	REVISION	DATE	BY	 Town of East Gwillimbury ENGINEERING DEPARTMENT <small>Our Town. Our Future.</small>
	1	ISSUED FOR REVIEW	2012/07/02	K.B.	
WATER TESTING & SAMPLING DETAIL					
					DRAWN: K.B. APPROVED: D.A. SCALE: N.T.S. DATE: JUNE, 2012



Town of
East Gwillimbury

APPENDIX 3

SANITARY SEWER DESIGN SHEET

Town of East Gwillimbury
Engineering Standards and Design Criteria

September 2012

TOWN OF EAST GWILLIMBURY SANITARY SEWER DESIGN SHEET



Town of
East Gwillimbury

Project / Subdivision _____

Prepared by: _____

Consulting Engineer _____

Checked by: _____

Project No. _____

Last Revised: _____

Design Parameters

As per Section F of Design Standards and Criteria

Design Equations

$$M(r) = \frac{1 + \frac{14}{4 + (P)}}{4 + (P)}$$

$$M(ind) = 6.6604 * A^{-0.1992}$$

$$Q(i) = i \times e^r \times A$$

$$Q(r) = \frac{P * q(r) * M}{86400}$$

$$Q(d) = e^r(Q(x))$$

NOTE: Section F of the Standards and Design Criteria Manual is to be referenced for Maximum Allowable Pipe Capacity

Location					Individual Values							Cumulative Values						Flow Data							Sewer Data																
Street	From		To		Industrial Area	Commercial Area	Institutional Area	Residential Area	Residential Units	Residential Population	Industrial P.F.	Industrial Area	Commercial Area	Institutional Area	Residential P.F.	Residential Area	Residential Population	Industrial Peak Flow (L/s)	Commercial Peak Flow (L/s)	Institutional Peak Flow (L/s)	Population Peak Flow (L/s)	Peak Extraneous Flow (L/s)	Total Design Flow (L/s)	Length	Pipe Size	Type of Pipe	Grade	Full Flow Capacity	Full Flow Velocity	Actual velocity at design flow											
	MH #	Inv	MH #	Inv	(ha)	(ha)	(ha)	(ha)	#	cap.	M(ind)	A(ind)	A(c)	A(ins)	M(r)	A(r)	P	Q(ind)	Q(c)	Q(ins)	Q(r)	Q(i)	Q(d)	(m)	(mm)		(%)	(L/s)	(m/s)	(m/s)											



Town of
East Gwillimbury

APPENDIX 4

STORM SEWER DESIGN SHEET

Town of East Gwillimbury
Engineering Standards and Design Criteria

September 2012



TOWN OF EAST GWILLIMBURY STORM SEWER DESIGN SHEET

Project / Subdivision _____
 Consulting Engineer _____
 Project No. _____

Prepared by: _____

Checked by: _____

Last Revised: _____

Design Parameters

A = drainage area (ha)
 C = runoff coefficient
 T_c = time of concentration (to be determined in accordance with Section G of Standards and Design Criteria Manual)

Design Equations

$I_{5yr} = 930 (t+4)^{-0.798}$ $Q = 2.78 \times A \times C \times I$

NOTE: Section G of the Standards and Design Criteria Manual is to be referenced for Maximum Allowable Pipe Capacity

Street	Location		Drainage Area Characteristics				Rainfall / Runoff			Sewer Data					Remarks		
	From MH.	To MH.	Area (ha)	C	AC	Accum. AC	T _c (min)	I (mm/hr)	Flow (L/s)	Diameter (mm)	Length (m)	Slope (%)	Cap. (L/s)	Vel. (m/s)		Sect. Time	Accum. Time



Town of
East Gwillimbury

APPENDIX 5

DESIGN STORMS

Town of East Gwillimbury
Engineering Standards and Design Criteria

September 2012

APPENDIX 5 – DESIGN STORMS

Table of Contents

1:2 Year, 4 Hour Design Storm	1
1:5 Year, 4 Hour Design Storm	1
1:10 Year, 4 Hour Design Storm	1
1:25 Year, 4 Hour Design Storm	2
1:50 Year, 4 Hour Design Storm	2
1:100 Year, 4 Hour Design Storm	2
Pond By-pass Design, 4 Hour Design Storm	3
1:2 Year, 24 Hour SCS Design Storm	4
1:5 Year, 24 Hour SCS Design Storm	5
1:25 Year, 24 Hour SCS Design Storm	6
1:100 Year, 24 Hour SCS Design Storm	7

APPENDIX 5 – DESIGN STORMS

1:2 Year, 4 Hour Design Storm

Use for peak flow analysis (i.e. HGL).
 Ptotal = 34.8 mm

Time hrs	Rain mm/hr	Time hrs	Rain mm/hrs	Time hrs	Rain mm/hr	Time hrs	Rain mm/hrs
0.167	2.3	1.167	4.8	2.167	11.0	3.167	2.9
0.333	2.5	1.333	6.1	2.333	7.2	3.333	2.6
0.500	2.7	1.500	8.6	2.500	5.4	3.500	2.4
0.667	3.0	1.667	15.0	2.667	4.4	3.667	2.2
0.833	3.5	1.833	82.0	2.833	3.7	3.833	2.1
1.000	4.0	2.000	25.0	3.000	3.2	4.000	2.0

1:5 Year, 4 Hour Design Storm

Use for peak flow analysis (i.e. HGL).
 Ptotal = 46.3 mm

Time hrs	Rain mm/hr	Time hrs	Rain mm/hrs	Time hrs	Rain mm/hr	Time hrs	Rain mm/hrs
0.167	2.8	1.167	6.2	2.167	14.0	3.167	3.6
0.333	3.1	1.333	7.9	2.333	9.2	3.333	3.3
0.500	3.4	1.500	11.0	2.500	6.9	3.500	3.0
0.667	3.8	1.667	20.0	2.667	5.6	3.667	2.7
0.833	4.4	1.833	113.0	2.833	4.7	3.833	2.6
1.000	5.1	2.000	24.0	3.000	4.1	4.000	2.5

1:10 Year, 4 Hour Design Storm

Use for peak flow analysis (i.e. HGL).
 Ptotal = 54.2 mm

Time hrs	Rain mm/hr	Time hrs	Rain mm/hrs	Time hrs	Rain mm/hr	Time hrs	Rain mm/hrs
0.167	3.4	1.167	7.2	2.167	16.0	3.167	4.3
0.333	3.7	1.333	9.2	2.333	11.0	3.333	3.9
0.500	4.1	1.500	13.0	2.500	8.1	3.500	3.6
0.667	4.6	1.667	22.0	2.667	6.6	3.667	3.3
0.833	5.2	1.833	136.0	2.833	5.6	3.833	3.2
1.000	6.0	2.000	38.0	3.000	4.9	4.000	3.1

1:25 Year, 4 Hour Design Storm

Use for peak flow analysis (i.e. HGL).

Ptotal = 62.2 mm

Time hrs	Rain mm/hr	Time hrs	Rain mm/hrs	Time hrs	Rain mm/hr	Time hrs	Rain mm/hrs
0.167	4.1	1.167	8.3	2.167	18.0	3.167	5.1
0.333	4.4	1.333	10.0	2.333	12.0	3.333	4.6
0.500	4.8	1.500	14.0	2.500	9.2	3.500	4.2
0.667	5.4	1.667	24.0	2.667	7.6	3.667	3.9
0.833	6.1	1.833	160.0	2.833	6.5	3.833	3.8
1.000	7.0	2.000	40.0	3.000	5.7	4.000	3.6

1:50 Year, 4 Hour Design Storm

Use for peak flow analysis (i.e. HGL).

Ptotal = 72.3 mm

Time hrs	Rain mm/hr	Time hrs	Rain mm/hrs	Time hrs	Rain mm/hr	Time hrs	Rain mm/hrs
0.167	4.3	1.167	9.2	2.167	21.0	3.167	5.4
0.333	4.7	1.333	12.0	2.333	14.0	3.333	4.9
0.500	5.1	1.500	16.0	2.500	10.0	3.500	4.5
0.667	5.7	1.667	29.0	2.667	8.3	3.667	4.1
0.833	6.5	1.833	190.0	2.833	7.0	3.833	3.9
1.000	7.6	2.000	50.0	3.000	6.1	4.000	3.8

1:100 Year, 4 Hour Design Storm

Use for peak flow analysis (i.e. HGL).

Ptotal = 78.1 mm

Time hrs	Rain mm/hr	Time hrs	Rain mm/hrs	Time hrs	Rain mm/hr	Time hrs	Rain mm/hrs
0.167	4.3	1.167	9.7	2.167	23.0	3.167	5.6
0.333	4.7	1.333	13.0	2.333	15.0	3.333	5.0
0.500	5.3	1.500	18.0	2.500	11.0	3.500	4.5
0.667	5.9	1.667	33.0	2.667	8.7	3.667	4.2
0.833	6.8	1.833	203.0	2.833	7.3	3.833	4.0
1.000	7.9	2.000	58.0	3.000	6.3	4.000	3.8

Pond By-pass Design, 4 Hour Design Storm

Use for peak flow analysis (i.e. pond by-pass).

P_{total} = 7.9 mm

Time hrs	Rain mm/hr	Time hrs	Rain mm/hrs	Time hrs	Rain mm/hr	Time hrs	Rain mm/hrs
0.167	0.5	1.167	1.0	2.167	2.4	3.167	0.6
0.333	0.5	1.333	1.3	2.333	1.6	3.333	0.5
0.500	0.6	1.500	1.9	2.500	1.2	3.500	0.5
0.667	0.6	1.667	3.4	2.667	0.9	3.667	0.5
0.833	0.7	1.833	19.4	2.833	0.8	3.833	0.4
1.000	0.9	2.000	5.8	3.000	0.7	4.000	0.4

1:2 Year, 24 Hour SCS Design Storm

Use to compute stormwater detention volumes.

Ptotal = 52.12 mm

Time hrs	Rain mm/hr	Time hrs	Rain mm/hrs	Time hrs	Rain mm/hr	Time hrs	Rain mm/hrs
0.20	.51	6.20	1.02	12.20	10.67	18.20	.76
0.40	.51	6.40	1.02	12.40	6.60	18.40	.76
0.60	.51	6.60	1.02	12.60	4.83	18.60	.76
0.80	.51	6.80	1.02	12.80	4.57	18.80	.76
1.00	.51	7.00	1.02	13.00	3.30	19.00	.76
1.20	.51	7.20	1.02	13.20	2.79	19.20	.76
1.40	.51	7.40	1.02	13.40	2.79	19.40	.76
1.60	.51	7.60	1.02	13.60	2.79	19.60	.76
1.80	.51	7.80	1.02	13.80	2.79	19.80	.76
2.00	.51	8.00	1.02	14.00	2.79	20.00	.76
2.20	.51	8.20	1.52	14.20	1.52	20.20	.51
2.40	.51	8.40	1.52	14.40	1.52	20.40	.51
2.60	.51	8.60	1.52	14.60	1.52	20.60	.51
2.80	.51	8.80	1.52	14.80	1.52	20.80	.51
3.00	.51	9.00	1.52	15.00	1.52	21.00	.51
3.20	.51	9.20	1.52	15.20	1.52	21.20	.51
3.40	.51	9.40	1.52	15.40	1.52	21.40	.51
3.60	.51	9.60	1.52	15.60	1.52	21.60	.51
3.80	.51	9.80	1.52	15.80	1.52	21.80	.51
4.00	.51	10.00	1.52	16.00	1.52	22.00	.51
4.20	1.02	10.20	3.05	16.20	1.02	22.20	.51
4.40	1.02	10.40	3.05	16.40	1.02	22.40	.51
4.60	1.02	10.60	3.05	16.60	1.02	22.60	.51
4.80	1.02	10.80	3.05	16.80	1.02	22.80	.51
5.00	1.02	11.00	3.05	17.00	1.02	23.00	.51
5.20	1.02	11.20	4.06	17.20	1.02	23.20	.51
5.40	1.02	11.40	5.84	17.40	1.02	23.40	.51
5.60	1.02	11.60	13.21	17.60	1.02	23.60	.51
5.80	1.02	11.80	28.96	17.80	1.02	23.80	.51
6.00	1.02	12.00	60.45	18.00	1.02	24.00	.51

1:5 Year, 24 Hour SCS Design Storm

Use to compute stormwater detention volumes.

Ptotal = 62.43 mm

Time hrs	Rain mm/hr	Time hrs	Rain mm/hrs	Time hrs	Rain mm/hr	Time hrs	Rain mm/hrs
.20	.76	6.20	1.27	12.20	12.19	18.20	1.27
.40	.76	6.40	1.27	12.40	7.62	18.40	1.27
.60	.76	6.60	1.27	12.60	5.59	18.60	1.27
.80	.76	6.80	1.27	12.80	5.08	18.80	1.27
1.00	.76	7.00	1.27	13.00	3.81	19.00	1.27
1.20	.76	7.20	1.27	13.20	3.05	19.20	1.02
1.40	.76	7.40	1.27	13.40	3.05	19.40	1.02
1.60	.76	7.60	1.27	13.60	3.05	19.60	1.02
1.80	.76	7.80	1.27	13.80	3.05	19.80	1.02
2.00	.76	8.00	1.27	14.00	3.05	20.00	1.02
2.20	.76	8.20	1.78	14.20	1.78	20.20	1.02
2.40	.76	8.40	1.78	14.40	1.78	20.40	1.02
2.60	.76	8.60	1.78	14.60	1.78	20.60	1.02
2.80	.76	8.80	1.78	14.80	1.78	20.80	1.02
3.00	.76	9.00	1.78	15.00	1.78	21.00	1.02
3.20	.76	9.20	1.78	15.20	1.78	21.20	.76
3.40	.76	9.40	1.78	15.40	1.78	21.40	.76
3.60	.76	9.60	1.78	15.60	1.78	21.60	.76
3.80	.76	9.80	1.78	15.80	1.78	21.80	.76
4.00	.76	10.00	1.78	16.00	1.78	22.00	.76
4.20	1.27	10.20	3.30	16.20	1.27	22.20	.76
4.40	1.27	10.40	3.30	16.40	1.27	22.40	.76
4.60	1.27	10.60	3.30	16.60	1.27	22.60	.76
4.80	1.27	10.80	3.30	16.80	1.27	22.80	.76
5.00	1.27	11.00	3.30	17.00	1.27	23.00	.76
5.20	1.27	11.20	4.57	17.20	1.27	23.20	.76
5.40	1.27	11.40	6.60	17.40	1.27	23.40	.76
5.60	1.27	11.60	15.24	17.60	1.27	23.60	.76
5.80	1.27	11.80	33.27	17.80	1.27	23.80	.76
6.00	1.27	12.00	69.60	18.00	1.27	24.00	.76

1:25 Year, 24 Hour SCS Design Storm

Use to compute stormwater detention volumes.

Ptotal = 95.96 mm

Time hrs	Rain mm/hr	Time hrs	Rain mm/hrs	Time hrs	Rain mm/hr	Time hrs	Rain mm/hrs
.20	1.02	6.20	2.03	12.20	18.80	18.20	2.03
.40	1.02	6.40	2.03	12.40	11.68	18.40	2.03
.60	1.02	6.60	2.03	12.60	8.38	18.60	2.03
.80	1.02	6.80	2.03	12.80	8.13	18.80	2.03
1.00	1.02	7.00	2.03	13.00	5.59	19.00	2.03
1.20	1.02	7.20	2.03	13.20	4.83	19.20	1.52
1.40	1.02	7.40	2.03	13.40	4.83	19.40	1.52
1.60	1.02	7.60	2.03	13.60	4.83	19.60	1.52
1.80	1.02	7.80	2.03	13.80	4.83	19.80	1.52
2.00	1.02	8.00	2.03	14.00	4.83	20.00	1.52
2.20	1.02	8.20	2.79	14.20	2.79	20.20	1.52
2.40	1.02	8.40	2.79	14.40	2.79	20.40	1.52
2.60	1.02	8.60	2.79	14.60	2.79	20.60	1.52
2.80	1.02	8.80	2.79	14.80	2.79	20.80	1.52
3.00	1.02	9.00	2.79	15.00	2.79	21.00	1.52
3.20	1.02	9.20	2.79	15.20	2.79	21.20	1.02
3.40	1.02	9.40	2.79	15.40	2.79	21.40	1.02
3.60	1.02	9.60	2.79	15.60	2.79	21.60	1.02
3.80	1.02	9.80	2.79	15.80	2.79	21.80	1.02
4.00	1.02	10.00	2.79	16.00	2.79	22.00	1.02
4.20	2.03	10.20	5.08	16.20	2.03	22.20	1.02
4.40	2.03	10.40	5.08	16.40	2.03	22.40	1.02
4.60	2.03	10.60	5.08	16.60	2.03	22.60	1.02
4.80	2.03	10.80	5.08	16.80	2.03	22.80	1.02
5.00	2.03	11.00	5.08	17.00	2.03	23.00	1.02
5.20	2.03	11.20	7.11	17.20	2.03	23.20	1.02
5.40	2.03	11.40	10.41	17.40	2.03	23.40	1.02
5.60	2.03	11.60	23.37	17.60	2.03	23.60	1.02
5.80	2.03	11.80	51.56	17.80	2.03	23.80	1.02
6.00	2.03	12.00	107.44	18.00	2.03	24.00	1.02

1:100 Year, 24 Hour SCS Design Storm

Use to compute stormwater detention volumes.

Ptotal = 112.42 mm

Time hrs	Rain mm/hr	Time hrs	Rain mm/hrs	Time hrs	Rain mm/hr	Time hrs	Rain mm/hrs
.20	1.27	6.20	2.29	12.20	21.84	18.20	2.29
.40	1.27	6.40	2.29	12.40	13.72	18.40	2.29
.60	1.27	6.60	2.29	12.60	9.91	18.60	2.29
.80	1.27	6.80	2.29	12.80	9.40	18.80	2.29
1.00	1.27	7.00	2.29	13.00	6.60	19.00	2.29
1.20	1.27	7.20	2.29	13.20	5.59	19.20	1.78
1.40	1.27	7.40	2.29	13.40	5.59	19.40	1.78
1.60	1.27	7.60	2.29	13.60	5.59	19.60	1.78
1.80	1.27	7.80	2.29	13.80	5.59	19.80	1.78
2.00	1.27	8.00	2.29	14.00	5.59	20.00	1.78
2.20	1.27	8.20	3.30	14.20	3.30	20.20	1.78
2.40	1.27	8.40	3.30	14.40	3.30	20.40	1.78
2.60	1.27	8.60	3.30	14.60	3.30	20.60	1.78
2.80	1.27	8.80	3.30	14.80	3.30	20.80	1.78
3.00	1.27	9.00	3.30	15.00	3.30	21.00	1.78
3.20	1.27	9.20	3.30	15.20	3.30	21.20	1.27
3.40	1.27	9.40	3.30	15.40	3.30	21.40	1.27
3.60	1.27	9.60	3.30	15.60	3.30	21.60	1.27
3.80	1.27	9.80	3.30	15.80	3.30	21.80	1.27
4.00	1.27	10.00	3.30	16.00	3.30	22.00	1.27
4.20	2.29	10.20	6.10	16.20	2.29	22.20	1.27
4.40	2.29	10.40	6.10	16.40	2.29	22.40	1.27
4.60	2.29	10.60	6.10	16.60	2.29	22.60	1.27
4.80	2.29	10.80	6.10	16.80	2.29	22.80	1.27
5.00	2.29	11.00	6.10	17.00	2.29	23.00	1.27
5.20	2.29	11.20	8.13	17.20	2.29	23.20	1.27
5.40	2.29	11.40	11.94	17.40	2.29	23.40	1.27
5.60	2.29	11.60	27.43	17.60	2.29	23.60	1.27
5.80	2.29	11.80	59.94	17.80	2.29	23.80	1.27
6.00	2.29	12.00	126.49	18.00	2.29	24.00	1.27



Town of
East Gwillimbury

APPENDIX 6

TYPICAL ENGINEERING DRAWINGS

Town of East Gwillimbury
Engineering Standards and Design Criteria

September 2012

APPENDIX 6 – TYPICAL ENGINEERING DRAWINGS

Table of Contents

Cover Sheet
General Notes Drawing
Typical Drawing Layout



Town of
East Gwillimbury

TOWN OF EAST GWILLIMBURY
XY □ DEVELOPMENT INC.

PROJECT NUMBER □□□□□□

TOWN OF E.G. PROJECT □ □□□□□□□

PLANNING PROJECT □ □□□□□□□

DEVELOPER	
CIVIL	
LANDSCAPE	
ELECTRICAL	

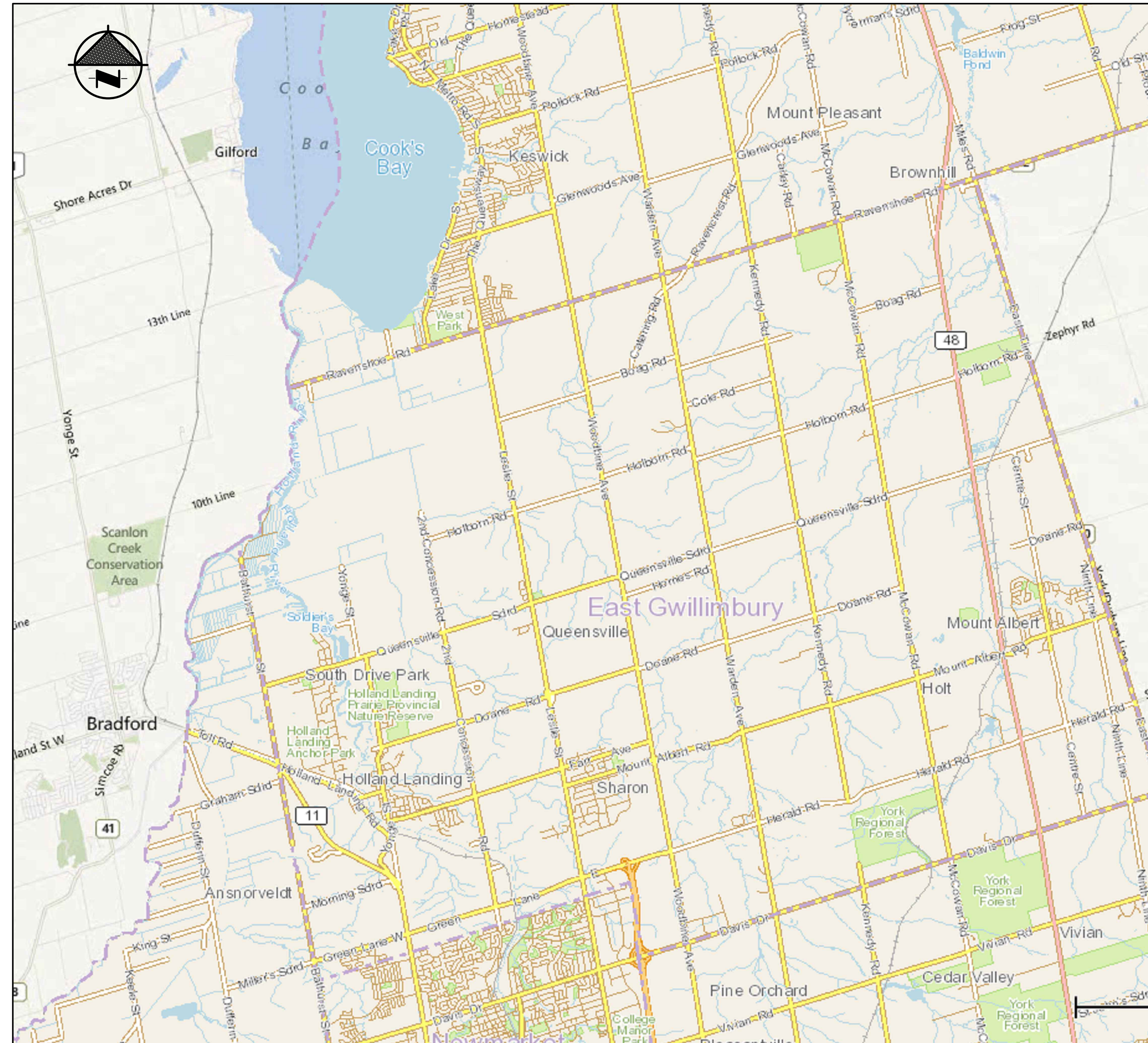

SITE LOCATION

SCALE: NTS

REVIEWED
TOWN OF E.G. ENGINEERING DEPT

SIGNATURE _____ DATE _____

TOWN OF EAST GWILLIMBURY GENERAL NOTES

PROJECT – SPECIFIC NOTES

1. General Notes

- All services are to be to the Town of East Gwillimbury Engineering Department Standards and Specifications and to the satisfaction of the Town.
- Locations of existing services is not guaranteed. The contractor is to notify utility companies forty-eight (48) hours prior to commencement of any work.
- For dimensions and details not shown, see Standard Drawing referred to on the profile.
- All works must be carried out according to the Occupational Health and Safety Act (updated 2011), Regulations for Construction Projects and all related Ontario regulations applicable to construction activity.
- Sewer and watermain trenches shall be backfilled to Town of East Gwillimbury Standards and compacted to a minimum of 5% Standard Proctor Density.
- All Standard drawings shall be per O.P.S.D. (most recent revision) unless otherwise specified.

2. Measurements

- All dimensions shall be in metres except pipe diameter which is in millimetres unless otherwise specified.

3. Roadworks

- Compaction: Road subgrade to be compacted to minimum 5% Standard Proctor Density. Granular materials are to be spread and compacted in 200 mm layers to a minimum of 100% Standard Proctor Density. Asphalt is to be compacted to minimum 6% Standard Proctor Density.

Item	Compaction Required (% of Standard Proctor Density)
Granular "B"	Minimum 96%
Granular "A" or 16 mm Crusher Run Stone	Minimum 100%
HL-6 or HL-8	Minimum 96%
HL-3	Minimum 96%

- Road Design - (Minimum)

Item	Compacted Thickness (Residential)
HL-3	40 mm
HL-6 or HL-8	50 mm
Granular "A" or 16 mm Crusher Run Stone	150 mm
Granular "B"	300 mm

Note: Asphalt and granular thickness may vary as recommended by the geotechnical report subject to the Town's approval.

- Curbs: Urban - Town Standard OPSD 600.040 or OPSD 600.010 (two-stage curb) Estate Residential - Town Standard OPSD 600.100
- Intersections of curbs and sidewalks shall be depressed, as per Standard OPSD 303.04.
- All areas disturbed by construction shall be reinstated to original or better condition.
- Sub-drains are to be installed throughout unless otherwise approved.
- No manhole covers will be permitted to be constructed in any part of the sidewalk.
- All new signs will be **Type IV high reflectivity** signs, made of steel and will include the Town name and year of manufacture on the border of the sign. Sign retro-reflectivity is determined using MUTCD Table 2A.3 (The standards in the OTM refer to new sign retro-reflectivity).

4. Storm Sewers

- All concrete pipe shall have sealed joints with gaskets and pipe class as shown on drawings.
- All PVC gravity sewer pipe shall be equal to ASTM Spec. D-3034-C SDR-35 with "lock-in" rubber sealing ring.
- Manholes:
 - Manholes shall be as per Standard Drawings OPSD 01.01 to 01.01 (inclusive).
 - All storm manholes to be benched throughout to the crown of all pipes on a vertical projection from spring line, as per Standard Drawings, except as otherwise noted.
- Sewer bedding shall be to Standard Drawing OPSD 02.03 Class "B" bedding or as approved by the Town.
- Catchbasins:
 - Catchbasins shall be as per standard drawings (OPSD).
 - Leads for a single catchbasin shall be 250 mm and for a double catchbasin 300 mm.
 - All catchbasins shall be connected to the storm sewer by tees where possible, Standard Drawings OPSD 00.01 and 00.02.
- All storm outfalls that empty into a ditch or watercourse must blend with the flow of same.
- All PVC joints at manholes shall be constructed by means of a PVC manhole adapter.
- Storm service connection shall be 150 mm PVC cleanout at property line. Services shall be extended 1.5 m inside the property line and plugged. Pipe to be white in colour. All services to be marked with 50 mm x 100 mm x 2.4 m stakes, painted white for storm.

5. Watermain

- Watermain pipe shall be PVC C-90 (Thick wall Pipe). Pipe is to be wrapped with strand 14-gauge strand copper wire and wire is to be brought to grade at all mainline valves and hydrant secondary valves and a hole drilled six (6) inches down from upper section and wire inserted through this hole for protection. Top of watermain shall be minimum 1.0 m below centreline of road grade. All splices are to be done above grade or using a moisture-proof seal.
- Hydrants and Valves shall be per Town Standards Drawing No. OPSD 1105.01. All hydrants are to be self-draining (unless in areas with high water table). All hydrants are to be equipped with one (1) four-inch (4") pumper port with manufacturer's "Stortz" fitting. Town-approved hydrants are Canada Valve (CanVal) - **ONLY**.
- Services:
 - Residential services shall be 15 mm Type "K" copper, as per Standard Drawing OPSD 1104.01 and have a minimum cover of 0.16 m.
 - All services shall be single services to the middle of the lot.
- All service connection stubs shall be marked with 50 mm x 100 mm x 2.4 m stakes, painted blue for water.
- All curb stops, main stops and couplings are to be compression-type fittings, i.e. Cambridge Successor ball valve type, which must be approved by the Town with stainless steel rods and brass pin.
- All bends and tees shall be OPSD 1103.01 and 1103.02 and blocked to undisturbed ground.
- Where the Town approves watermain construction with less than the above noted minimum cover, the watermain shall be insulated to the Town's satisfaction.
- All mechanical connections shall be protected against corrosion through the use of corrosion protection duration nuts. Nuts shall be used on 50 mm or all T-bolts per connection and are to be used in addition to standard fastening nuts, not in place of standard nuts.

6. Sanitary Sewers

- Pipe:
 - All PVC gravity sewer pipe shall be equal to A.S.T.M. Specifications D-3034-C with "lock-in" rubber sealing ring.
 - All house services shall be connected to sewer with tees. Pipe: 125 mm PVC cleanout 125 mm PVC watertight cleanout at property line. Services shall be extended 1.5 m inside the property line and plugged. Pipe to be green in colour. All services to be marked with 50 mm x 100 mm x 2.4 m stakes, painted green for sanitary.
 - All sewer connections to manholes shall be constructed by means of a PVC manhole adapter.
 - The bedding material shall extend to 300 mm above the pipe and compaction tests are required before the trench is backfilled. Backfill shall be compacted to minimum 5% Standard Proctor Density.
- Manholes:
 - Manholes shall be to Standard Drawings OPSD 01.01 to 01.01 (inclusive).
 - All sanitary manholes shall be benched throughout to the spring line, as per Standard Drawings, except as otherwise noted.
 - All sanitary manholes shall have monolithic pre-benched bases with pre-manufactured connections.
 - All sanitary manholes constructed in the vicinity of low points or outside of the paved roadway shall have watertight covers. All manholes located in cul-de-sacs shall have watertight covers.
- Sanitary sewer bedding shall be to Standard Drawing OPSD 02.03 Class "B" (unless otherwise noted and approved).
- Laterals - all laterals shall be constructed according to Standard Drawings OPSD 1006.01 and 1006.02.

7. Survey Monument Information

Record of monuments to be constructed with the project:

- Survey monument No. 1

Location []

Elevation []

UTM Coordinates []

- Survey monument No. 2

Location []

Elevation []

UTM Coordinates []

LEGEND

	EXISTING WATERMAIN
	EXISTING SANITARY SEWER
	EXISTING STORM SEWER
	EXISTING CATCHBASIN LEAD
	EXISTING GAS MAIN
	EXISTING U/G BELL
	EXISTING U/G HYDRO
	EXISTING U/G CABLE TELEVISION
	EXISTING BELL PEDESTAL
	EXISTING HYDRO TRANSFORMER & PAD
	EXISTING UTILITY POLE WITH GUY WIRE
	EXISTING HYDRANT AND VALVE
	EXISTING VALVE CHAMBER
	EXISTING VALVE & BOX
	EXISTING GAS VALVE
	EXISTING MH STORM OR SANITARY
	EXISTING CATCHBASIN SINGLE
	EXISTING CATCHBASIN DOUBLE
	IRON BAR
	STANDARD IRON BAR
	EXISTING CURB & GUTTER
	EXISTING CULVERT
	EXISTING FENCE
	EXISTING DECIDUOUS TREE
	EXISTING CONIFEROUS TREE
	EXISTING VEGETATION TO BE REMOVED
	EXISTING SIGN
	PROPOSED STORM MAINTENANCE HOLES
	PROPOSED CATCHBASIN MAINTENANCE HOLES
	PROPOSED SANITARY MAINTENANCE HOLES
	PROPOSED SEWER
	POSSIBLE PIPE DISCHARGE TO EXISTING DITCH
	PROPOSED WATERMAIN
	PROPOSED BOULEVARD CATCHBASIN
	PROPOSED CATCHBASIN
	PROPOSED DOUBLE CATCHBASIN
	PROPOSED HYDRANT & SECONDARY VALVE
	PROPOSED VALVE & CHAMBER
	PROPOSED CURB & GUTTER & DEPRESSION
	PROPOSED SIDEWALK
	RESTORE DRIVEWAY WITH GRAVEL
	RESTORE DRIVEWAY WITH ASPHALT
	RESTORE DRIVEWAY WITH CONCRETE
	RESTORE DRIVEWAY WITH PAVING STONE
	DIRECTION OF DRIVEWAY APRON DRAINAGE
	PROPOSED ELEVATION
	EXISTING ELEVATION
	EXISTING STRUCTURE TO BE REMOVED
	EXISTING SAN LATERAL CONNECTIONS
	CONNECTIONS TO EXISTING WATER SERVICE AT PROP. AND EX. WATERMAINS

4				
3				
2				
1				

No.	Revision	Date	By	Appr.

No.	Elevation	Description

 CONSULTANT LICENSED PROFESSIONAL ENGINEER PROVINCE OF ONTARIO	REVIEWED TOWN OF E.G. ENGINEERING DEPT. SIGNATURE _____ DATE _____
---	--

Town of East Gwillimbury
Our Town, Our Future

(CONSULTANTS COMPANY
INFO & LOGO)

(PROJECT NAME)
GENERAL NOTES

Surveyed by:	Checked by:	Project No.:
Drawn by:	Approved by:	??-??
Designed by:	Date:	Drawing No.:
Scale:	0m 10m 20m	GN
Horz. 1:500	0m 1m 2m	Sheet No.:
Vert. 1:50		- OF -

